

STRUCTURAL ANALYSIS REQUIRED WHEN THIS DIMENSION EXCEEDS 1'-6"

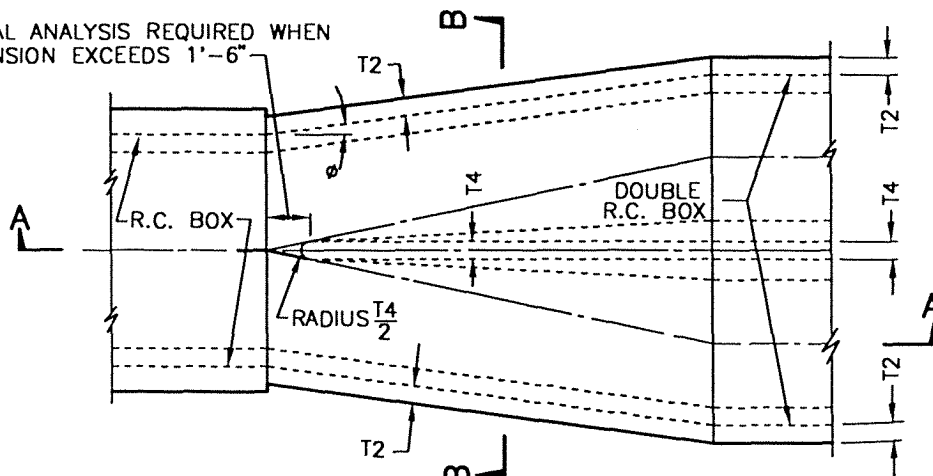

PLAN

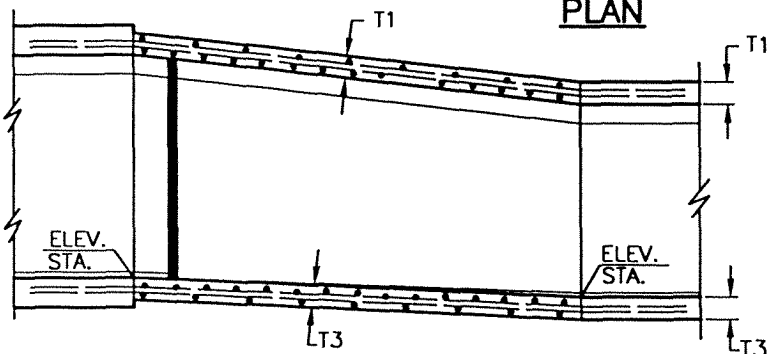

SECTION A-A

STEEL PATTERN SHOWN IS PICTORIAL ONLY. SEE PROJECT DRAWINGS FOR ACTUAL LAYOUT.

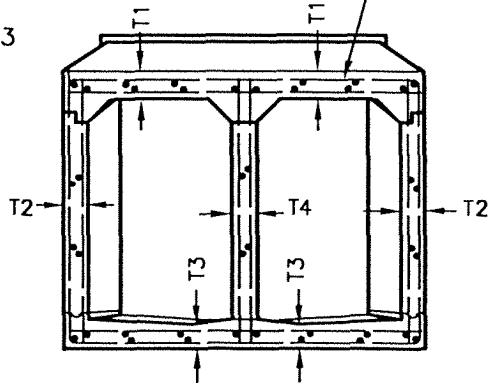

SECTION B-B

**NOTES:**

1. THE HORIZONTAL ANGLE OF DIVERGENCE OR CONVERGENCE,  $\phi$ , SHALL NOT EXCEED 5 DEGREES 45 MINUTES.
2. REINFORCING STEEL BAR SIZE, SPACING AND OUTSIDE COVER SHALL BE THAT OF DOUBLE BOX SECTION. FOR CURVED TRANSITIONS, SPACE BARS ON CENTER LINE AND PLACE TRANSVERSE RADIALLY. THE BAR LENGTHS AND DIMENSIONS SHALL VARY UNIFORMLY THROUGHOUT TRANSITION. LONGITUDINAL BARS SHALL BE CONTINUED THROUGH THE JOINTS WITH THE TRANSITION STRUCTURE.
3. THE CONCRETE THICKNESS SHALL BE THAT OF THE DOUBLE BOX SECTION.
4. PLAN AS SHOWN IS FOR DOUBLE BOX SECTION DOWNSTREAM. WHEN DOUBLE BOX SECTION IS UPSTREAM, TAPER THE LAST 2 FEET OF CENTER WALL TO END IN 1/2 INCH RADIUS.
5.  $f'c = 4000$  AT 28 DAYS .
6. TRANSVERSE JOINT KEYWAYS, AS DETAILED FOR LONGITUDINAL JOINT KEYWAYS AT BASE OF OUTLET WALLS ON THE PROJECT DRAWINGS, SHALL BE PLACED IN BOTH SLABS AND WALLS AT THE END OF EACH POUR.
7. ALL STEEL, EXCEPT LONGITUDINAL STEEL SHALL BE GRADE 60 BILLET STEEL CONFORMING TO ASTM A 615 AND SHALL TERMINATE 1/2" CLEAR OF CONCRETE SURFACE UNLESS OTHERWISE SHOWN.

REV.	APPR. BY	DATE

REV.	APPR. BY	DATE

<p>CITY OF <b>Oxnard</b></p>	<p><b>TRANSITION STRUCTURE No. 3</b> SINGLE BOX TO DOUBLE BOX</p>		<p>STANDARD PLAN 2002</p>
	<p>DRAWN: STAFF    CKD.: STAFF</p>	<p>APPR. <i>Granville M. Bowman</i></p> <p>Granville M. Bowman</p>	<p><b>PLATE 533</b></p> <p>SHEET 1 OF 1</p>
<p>Department of Public Works</p>			