

REV.	APPR.	BY	DATE

REV.	APPR.	BY	DATE

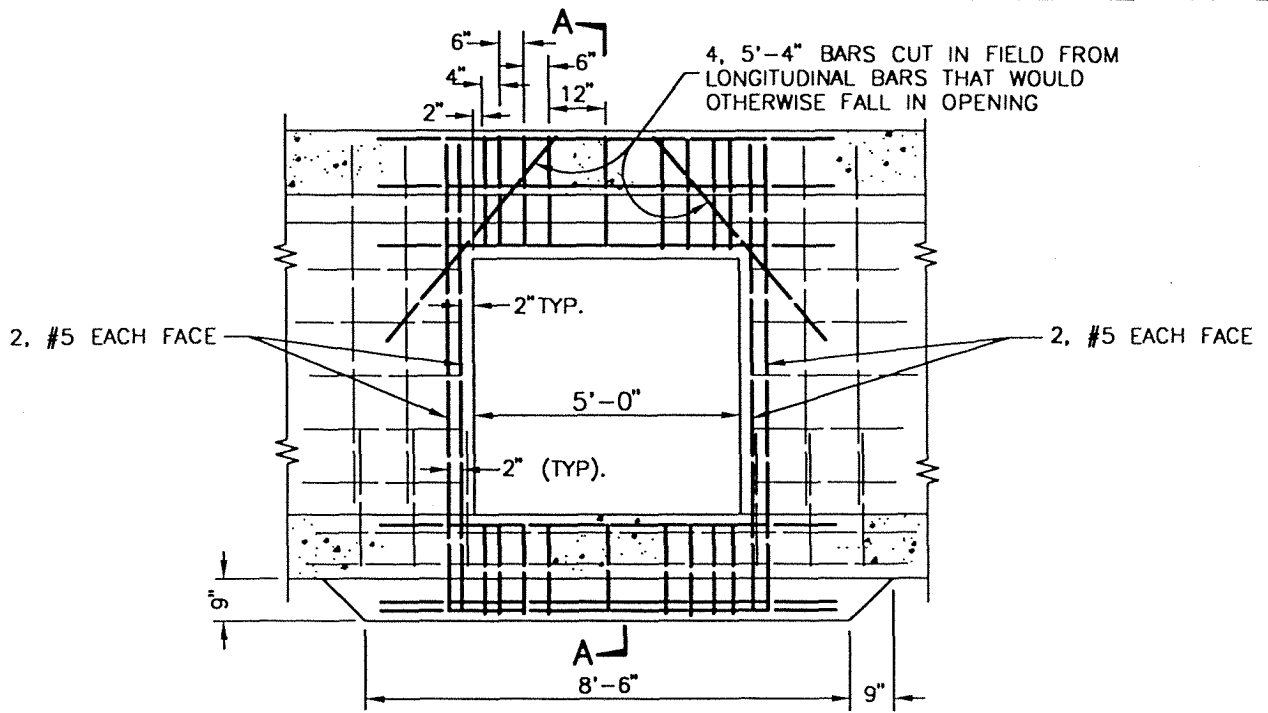

ELEVATION

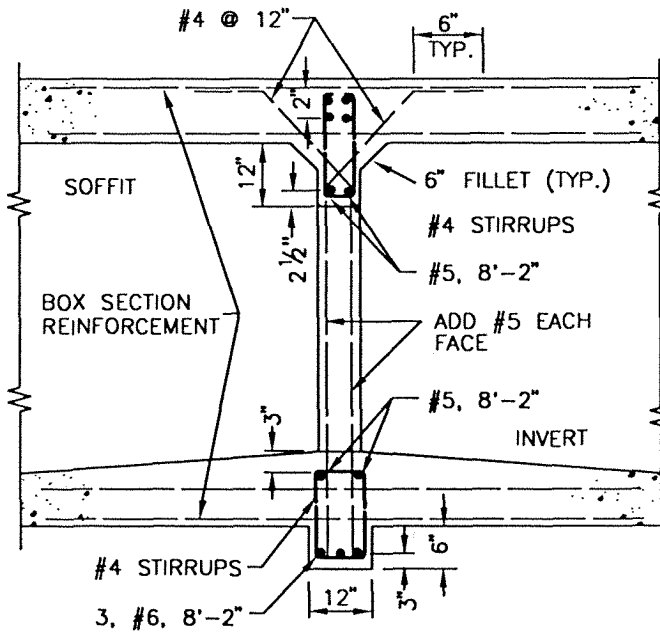

SECTION A-A

NOTES:

1. THIS STRUCTURE TO BE USED WHERE:
 - a. DEPTH OF COVER DOES NOT EXCEED 10'.
 - b. CLEAR SPAN OF ONE BARREL DOES NOT EXCEED 12'
2. LONGITUDINAL BARS TO BE CUT IN FIELD 2" FROM OPENING.
3. ROUND ALL EDGES TO 2" RADIUS.
4. NO TRANSVERSE CONSTRUCTION JOINT TO BE PLACED WITHIN 5' OF WINDOW.

 <p>CITY OF</p>	WINDOW DETAILS FOR MULTIPLE BOX SECTION		STANDARD PLAN 2002
	DRAWN: STAFF	CKD.: STAFF	 APPR. Granville M. Bowman
Department of Public Works			