

ALHAMBRA A-1490

COVER WT. = 263 lbs.
 FRAME WT. = 210 lbs.
 TOTAL WT. = 473 lbs.

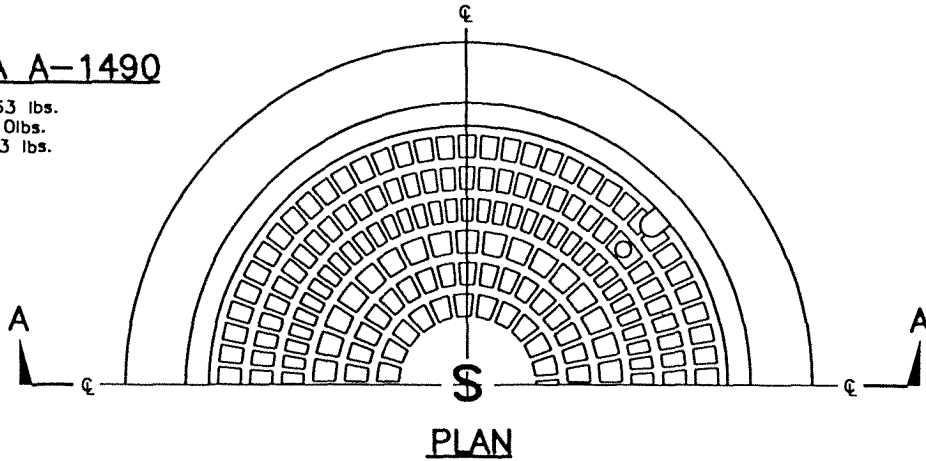

PLAN

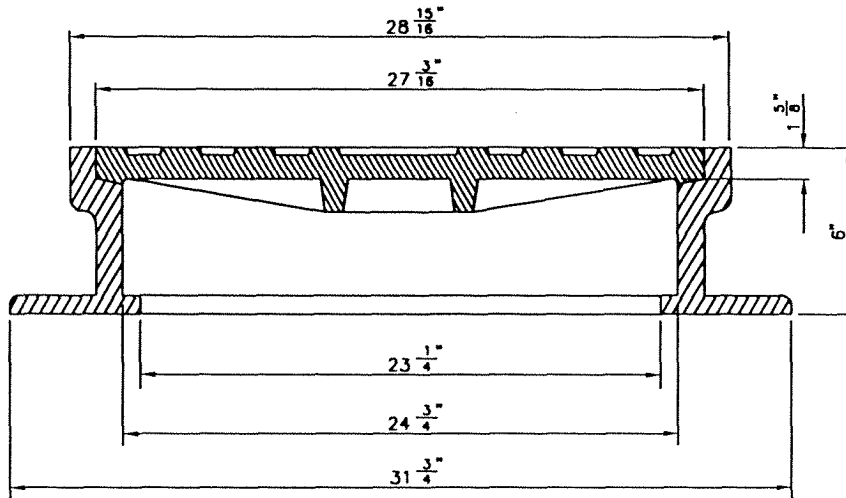

SECTION A-A

NOTES:

1. MANHOLE FRAMES AND COVERS SHALL BE MADE OF GRAY CAST IRON CONFORMING TO ASTM A-48-64 AND PAINTED WITH ASPHALTUM PAINT. ALHAMBRA 1490 OR APPROVED EQUAL.
2. FOUNDRY MARK SHALL BE SHOWN ON THE FRAME AND ON THE BOTTOM OF THE COVER.
3. COVERS SHALL BEAR THE LETTER "D" FOR STORM DRAINS AND "S" FOR SEWERS. THE LETTERS SHALL BE APPROXIMATELY 2 1/2" HIGH WITH 1/2" LINE WIDTH AND PLACED IN THE CENTER OF THE COVER. COVERS SHALL ALSO BEAR THE AGENCY'S IDENTIFICATION IN ACCORDANCE WITH INSTRUCTIONS FURNISHED BY THE AGENCY. ALL LETTERS SHALL BE FLUSH WITH THE FINISHED SURFACE OF THE COVER.
4. COVERS FOR MANHOLES LOCATED IN EASEMENTS, PARKWAYS, AND ALL OTHER PLACES EXCEPT PAVED STREETS OR ALLEYS SHALL BE PROVIDED WITH ALLEN SOCKET SET SCREW LOCKING DEVICES. THE CONTRACTOR SHALL DRILL AND TAP TWO HOLES TO A DEPTH OF 1 INCH AT 90 DEGREES TO PICK HOLE AND INSTALL 3/4-BY-3/4-INCH ALLEN SOCKET SET SCREWS.
5. THE WEIGHT OF THE COVER SHALL NOT VARY MORE THAN FIVE PERCENT FROM THAT SHOWN.

REV.	APPR. BY	DATE

REV.	APPR. BY	DATE

 <p>CITY OF</p>	MANHOLE FRAME AND COVER		STANDARD PLAN 2002
	DRAWN: STAFF	CKD.: STAFF <i>[Signature]</i>	APPR. <i>[Signature]</i> Granville M. Bowman
Department of Public Works			SHEET 1 OF 1