

NOTES:

1. AGGREGATE BASE REQUIRED UNDER CROSS GUTTER BEGINNING AT B.C.R. & E.C.R. & UNDER SPANDREL.
2. ——— INDICATES 1/2" EXPANSION JOINT OR COLD JOINT.
3. REBAR, #4 SIZE, 12" ON CENTER, BOTHWAYS, GUTTER AND SPANDREL.
4. ALL CONCRETE SHALL BE CLASS 520-A-2500 WITH 2LBS OF 3/4" LONG POLYPROPYLENE FIBERS PER CUBIC YARD.
5. FOR SIDEWALK TREATMENT AROUND THE CURB RETURN, CURB RADIUS, AND RIGHT-OF-WAY REQUIREMENTS, SEE NEXT SHEET.
6. APPLY WEED KILLER AT ALL COLD JOINTS.
7. INSTALL 2" DEEP WEAKENED PLANE JOINTS AT 20' INTERVALS.

WIDTH OF DRIVEWAY

TYPE OF STREET	RESIDENTIAL		COMMERCIAL/ INDUSTRIAL		ARTERIAL	
	MIN	MAX	MIN	MAX	MIN	MAX
TYPE OF DEVELOPMENT						
RESIDENTIAL	12	25	—	—	—	—
COMMERCIAL	ONE WAY TRAFFIC	—	18	25	20	30
	TWO WAY TRAFFIC	—	25	36	25	36
INDUSTRIAL PASSENGER CARS	ONE WAY TRAFFIC	—	18	25	20	30
	TWO WAY TRAFFIC	—	25	36	25	36
INDUSTRIAL TRUCKS	—	—	25	45	25	45



COMMERCIAL & INDUSTRIAL DRIVEWAYS

STANDARD PLAN 2002

DRAWN: A. ROQUE CKD.: HUNG LE

PLATE 116

Department of Public Works

APPR. *L. Balderrama*
L. Balderrama, PE, City Engineer

SHEET 1 OF 2

REV. APPR. BY DATE

REV. APPR. BY DATE

L. Balderrama 09/10/10

REV.	APPR.	BY	DATE

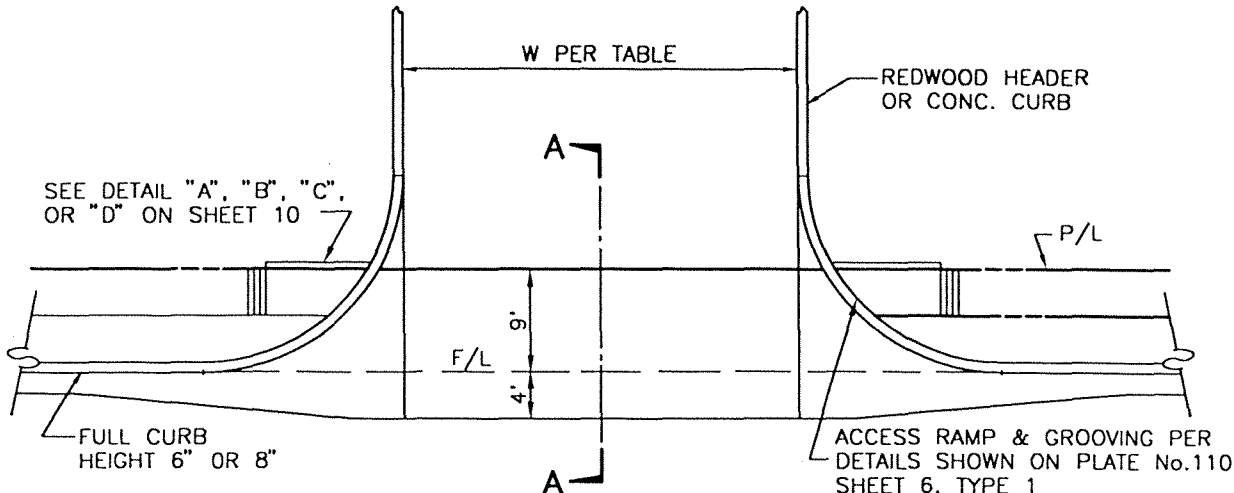

PLAN VIEW

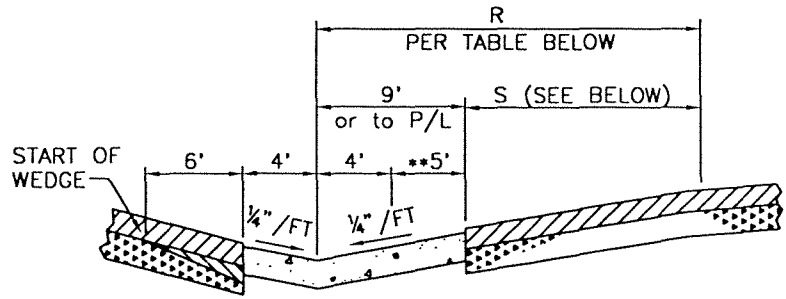

SECTION A-A

TYPE OF ROADWAY	R	S	
		6" CF	8" CF
ARTERIAL ROADWAY (PLATE No. 102)	35'	4.0%	4.6%
COMMERCIAL/LOCAL ARTERIAL (PLATE No. 101)	25' *	5.2%	6.2%
IN FILL AREA (SPECIAL CASE) PRIOR APPROVAL BY PWD REQUIRED	20'	6.6%	8.1%

* IF PREDOMINANTLY USED BY TRUCKS, USE R=35'
 ** FIVE FOOT OF GUTTER WIDTH TO HAVE 2% MAX. CROSSFALL FOR DISABLED ACCESS PATHWAY AND TO ALIGN WITH RAMPS.

REV.	APPR.	BY	DATE

	CITY OF Oxnard		COMMERCIAL & INDUSTRIAL DRIVEWAYS		STANDARD PLAN 2002
	DRAWN: STAFF	CKD.: STAFF	APPR. <i>Granville M. Bowman</i> Granville M. Bowman		PLATE 116
Department of Public Works				SHEET 2 OF 2	