

CITY OF OXNARD - TRAFFIC SIGNAL SPECIFICATIONS
Revised January 2018

0. SCOPE

The work under this Section shall consist of furnishing and installing traffic signals, battery back-up systems, interconnect circuits, and safety lighting as indicated on the plans. All work shall conform to the provisions of the 2015 Standard Specifications, Revised Standard Specifications, Standard Plans and Revised Standard Plans of the State of California, Department of Transportation and these Special Provisions. All work shall also conform to the provisions of the "Transportation Electrical Equipment Specifications" (TEES), the "Traffic Signal Control Equipment Specifications" (TSCES), issued by the State of California, the Institute of Traffic Engineers (ITE) publication: ST-017B. Where the Standard Specifications and Standard Plans of the State of California refer to [the Institute of Traffic Engineers (ITE) publication: ST-008B], it shall read [the Institute of Traffic Engineers (ITE) publication: ST-017B] in lieu of publication: ST-008B.

Furnishing and installing traffic signals and highway lighting shall conform to the provisions in Sections 86 and 87, "Electrical Systems" of the 2015 State Standard Specifications, Revised Standard Specifications, and State Standard Plans and these Special Provisions. The State Standard Specifications shall hereinafter may be referred to as the SSS, Revised Standard Specifications hereinafter may be referred to as RSS, State Standard Plans hereinafter may be referred to as the SSP and Revised Standard Plans hereinafter may be referred to as RSP.

1. WORK TO BE ACCOMPLISHED

Furnish and install controller assembly, traffic signal poles, mast arms, signal heads, pedestrian heads, pedestrian push button assemblies, lighting systems, non-illuminated street name signs, mast arm signs, pull boxes, detection loops, conduits and conductors, emergency vehicle preemption, service enclosure, and battery backup system shown on the plans as specified in these Special Provisions, and in conformance to (TEES), (TSCES), the State Standard Specifications Sections 86 and 87, and the State Standard Plans.

The locations of signal poles and appurtenances shown on the plan are approximate and the Engineer in the field or his representative will establish the exact locations.

2. CONDUITS – TRAFFIC SIGNAL

Conduit and conduit installation shall be in accordance with Section 86-1.02B "Conduit and Accessories" and Section 87-1.03B "Conduit Installation" of the Standard Specifications. Type 1 conduit shall be used for all conduit runs except where noted on the plans. Insulated bonding bushings shall be required on all metal conduits.

Non-metallic type conduit shall not be used for signal installation, except for detector loop "stub out" conduits.

Where conduits terminate inside a pull box the top of the conduit with ground bushing installed shall be a minimum of (5") and a maximum of (7") below the top of the pull box.

Conduit for all loop "stub outs" shall be 2-inch schedule 40 PVC. The end of the loop conduit in the roadway shall be 5" below the surface of the roadway. When a loop "stub out" is to be placed where no gutter and/or curb exists, the end of the conduit shall extend into the roadway a minimum of 8" from the edge of the pavement.

After conductors have been installed, the ends of conduits terminating in pull boxes, service enclosures, controller cabinets, and under roadway surfaces shall be sealed with an approved type of sealing compound.

Rigid metal conduit, to be used as a drilling or jacking rod, shall be fitted with suitable drill bit for the size of the hole required.

At locations where conduit is to be installed under pavement, and in the event that obstructions are encountered, upon approval of the Engineer, small holes may be cut in the pavement to locate and/or remove obstructions. Jacking or drilling pits shall be kept at a minimum of 2 feet clear of the edge of any type of pavement wherever possible.

Installation by the "Trenching in Pavement Method" shall not be allowed under normal circumstances.

3. CONDUITS – TRAFFIC SIGNAL INTERCONNECT

All conduits shall be high density polyethylene (HDPE) Schedule 80 UL continuous conduit. HDPE conduit shall be designed and engineered for direct burial, directionally drilled installation, or encased underground applications.

The size of the HDPE conduit shall be as shown on the plans and shall meet the following requirements:

1. The HDPE Schedule 80 continuous conduit shall conform to NEMA TC-2 and UL651B
2. The conduit leading to splice vaults or pull boxes shall be terminated with a manufacture-produced terminator connector to seal the wall of the splice vault/pull box.
3. The conduit shall also be marked with data traceable to plant location, date, shift and machine of manufacture.
4. Conduit shall be Carlon or Endot made or approved equivalent.

Rigid Galvanized Steel (RGS) conduit shall be installed at locations where conduit is exposed, such as the installation of conduit under existing railroad structure or alongside and underside of a bridge. The RGS conduit shall be per Caltrans Standards Specification 86-1.02B and shall be Type 2 hot-dipped galvanized steel with exterior thermoplastic coating.

All conduits shall be free from defects including non-circularity, foreign inclusions, etc. It shall be nominally uniform (as commercially practical) in color, density and physical properties.

If new conduit is being installed into an existing pull box #6 or #6E location, the existing pull box shall be replaced. Should the existing pull box and/or conduit become damaged, the damaged pull box and/or conduit shall be replaced at no cost to the City. Prior to replacement of damaged pull box and/or conduit, the City shall be notified of exact location and contents of damaged pull box and/or conduit.

All pavement markings that are disturbed shall be replaced within thirty (30) calendar days. All work shall be approved by the Engineer.

Written approval from the Engineer shall be obtained before installing any conduits.

All conduits shall be new, UL listed and meet NEMA and NEC requirements pertaining to electrical conduits and components.

All conduits shall be installed by directional drilling method except for exposed installation or as directed by the Engineer. The method of installation shall be determined by the Engineer to suit the existing field conditions. Drilling pits shall be kept at least two (2) feet clear of the edge of any type of pavement wherever possible.

Conduit shall have a minimum of thirty (30) inches of cover to the top of the conduit is required at all locations.

Conduit shall be placed in a manner to allow the cable/wire to be pulled in a straight line and clear the side of the pull box by at least two (2) inches.

Where conduits are shown on the plans to be installed parallel and adjacent to each other, they shall be installed together in a common trench or directional drill bore.

Make right angle bends in conduit runs with long-radius elbows or conduits bent to radii not less than three (3) feet.

All bend radii shall be three (3) feet unless otherwise set forth elsewhere in this Special Provision or as directed by the Engineer. The sum of the angles for conduit bends between two consecutive pull boxes shall not exceed 270 degrees. All conduit bends shall be factory bends done by the manufacturer. Hot box or other field bends will not be accepted. The bell and spigot ends of each PVC conduit shall be chamfered by the manufacturer. Transition of the conduit without bends shall not exceed more than one foot for every ten feet.

Make bends and offsets so that the inside diameter of conduit is not effectively reduced. Unless otherwise indicated, keep the legs of a bend in the same plane and the straight legs of offsets parallel.

Do not use diagonal runs except when specifically noted in the drawings.

Provide waterproof label on each end of the pull wire to indicate the destination of the other end.

Conduits entering vaults shall terminate flush with the inside walls of each pull box.

Conduits entering vaults and pull boxes shall be capped or sealed to prevent ingress of water, debris and other foreign matters into the conduit.

Immediately prior to installing cables, conduits shall be blown out with compressed air until all foreign material is removed. After cables have been installed, the ends of conduits shall be sealed with a reusable mechanical plug.

Conduit and fittings shall be supplied with an ultraviolet inhibitor.

Except for pull boxes with extensions, conduit shall enter the pull box at not more than a 45-degree angle. In addition, conduit may not be terminated less than 45 degrees to the ground level, except for pull boxes with extension. Conduit ends shall be terminated three (3) inches above the gravel surface (bottom of pull box) and nine (9) inches clearance between the top of the bushing and the top of the pull box shall be provided.

For pull boxes with extensions or vaults, conduit shall enter the side of the pull box or vault at not more than a 15-degree angle. Conduit ends shall be terminated no more than three (3) inches inside the pull box or vault at height of 12 inches above the gravel surface (bottom of pull box) and twelve (12) inches clearance between the top of the conduit and the top of the pull box shall be provided.

Within the splice vault, the conduit shall be laid no closer than two (2) inches from any wall of the splice vault.

After conductors/cables have been installed, the exposed end of conduits remaining in pull boxes and controller cabinets shall be sealed with a sealing compound as approved by the Engineer.

If trenching in City of Oxnard right of way is allowed by the Engineer or as shown on the plan, it shall conform to the City of Oxnard Standards.

Installation of conduit in unpaved areas (dirt) shall conform to the following:

- a. Conduit shall be placed in a trench approximately two (2) inches wider than the outside diameter of the conduit to be installed. Trench shall not exceed eight (8) inches in

width. A minimum of thirty (30) inches of cover to the top of the conduit is required. For all pull boxes, the trench may be hand dug to required depth.

- b. Where cover to top of conduit is less than thirty (30) inches, the conduit shall be placed in the bottom of the trench and shall be backfilled with sand-cement slurry backfill containing not less than two (2) sacks (188 pounds) of cement per cubic yard of Type I or II Portland cement added per cubic yard of imported sand and sufficient water for workability. The top four (4) inches shall be backfilled and compacted with native soil.

4. PULL BOXES – TRAFFIC SIGNAL

Pull boxes shall conform to the provisions in Section 86-1.02C “Pull Boxes”, Section 87-1.03C “Installation of Pull Boxes”, and the Revised Standard Plans ES-8A and ES-8B.

Plastic pull boxes and pull box covers shall not be used. All pull boxes and pull box covers shall be made of reinforced Portland cement concrete.

The word “CALTRANS” shall not be included on pull box covers. All pull box covers shall be marked "TRAFFIC SIGNAL" unless otherwise noted in the plan. Hold down bolts for concrete covers will not be required.

Where new conduit is to be installed into an existing pull box, the contractor shall remove and dispose of the existing pull box and shall furnish a new pull box of equal or greater size.

Where concrete or asphalt is to be removed around an existing pull box, the contractor shall remove and dispose of the existing pull box and shall furnish a new pull box of equal or greater size.

Pull boxes shall not be placed in any wheel chair ramp or driveway. Pull boxes placed in dirt areas shall have a minimum of 2" of the pull box exposed above the surrounding grade.

5. PULL BOXES – TRAFFIC SIGNAL INTERCONNECT

Pull boxes shall conform to the provisions in Section 86-1.02C “Pull Boxes”, Section 87-1.03C “Installation of Pull Boxes”, Revised Standard Plans ES-8A and these Special Provisions for TRAFFIC pull boxes.

Pull boxes and covers in the sidewalk or behind the curb shall be composite, Christy “Fiberlite”, Armorcast polymer concrete or Engineer Approved equivalent, unless, otherwise noted on the Plans.

The cover markings for each pull box shall read “TRAFFIC – FIBER” on one line.

All Traffic-Rated pull boxes shall have vertical proof-load strength of 25,000 lbs. This load shall be placed anywhere on the box and cover for a period of one minute without causing any cracks or permanent deformations.

Where pull boxes are installed in sidewalk, sidewalk shall be removed and replaced from score line to score line as directed by the Engineer.

All pull boxes shall be installed at the locations shown on the Plans or as directed by the Engineer. However, these locations may be changed to suit field conditions as directed or approved by the Engineer.

No pull box shall be located on the driveway apron or above catch basin or within one (1) foot of any existing, proposed or future (as shown on plans) wheelchair ramp or within one (1) foot from the curb in case of street without gutter or within thirty (30) inches from any pole foundation or other locations which may interfere with the movement of people or vehicles, unless approved by the Engineer.

Pull boxes within unimproved areas shall have a Class 1 flexible Post Delineator, per Caltrans Standard Plan A73C installed adjacent to the pull box.

Within the pull box without extensions, the conduit shall be placed in a manner that the lowest portion of the opening shall be three (3) inches above the bottom of the pull box. The top portion of the conduit shall be nine (9) inches from the top of the pull box. The maximum thickness of the grout shall be one (1) inch.

Within the pull box with extensions, the conduit shall enter from the side of the pull box in a manner where the top of the conduit shall be twelve (12) inches above the bottom of the pull box. The maximum thickness of the grout shall be one (1) inch.

The conduit shall also be placed in a manner to allow the cable/wire to be pulled in a straight line and clear the side of the pull box by at least two (2) inches.

The distance between pull boxes shall not exceed five hundred (500) feet, unless otherwise specified in the Plans or these Special Provisions, or as directed by the Engineer.

A minimum of fifteen (15) feet slack of cable, or length as shown on the plans, shall be coiled in each pull box at all locations, unless otherwise specified in the Plans or these Special Provisions, or as directed by the Engineer.

If new pull boxes are replacing existing pull boxes or intercepting existing conduits, the Contractor shall make modifications to conduit entering pull box including the modification of conduit ends to support the cable and/or the replacement of elbows with sweeps, without causing any damage to the existing conduit and cables. Should the existing conduit or cable become damaged, the conduit or cable shall be replaced at no cost to the City. Prior to replacement, the City or the Engineer shall be notified of exact location and shall be provided with a detailed description of the damage. No additional compensation will be allowed for replacement.

Any existing features or improvements damaged during installation shall be replaced in kind without cost to the City.

Pull boxes shall be installed with lid and completely secured prior to any conductor or cable installation.

Where the sump of an existing pull box is damaged during the installation operations, the sump shall be reconstructed and if the sump was grouted, the old grout shall be removed and new grout shall be placed at no cost to the City.

Excavating and backfilling shall conform to the provision in Section 87-1.03E, "Excavating and Backfilling for Electrical Systems" of Caltrans Standard Specifications except that the backfill material shall not contain rocks graded larger than one (1) inch.

6. FOUNDATIONS

Foundations shall conform to the provisions in Section 87-1.03E(3) , "Concrete Pads, Foundations, and Pedestals", of the SSS and these Special Provisions.

The elevation of the top of controller cabinet foundation above the surrounding pad or sidewalk elevation shall be 12 inches in lieu of the 3.5 inches shown on Standard Plan ES-3C.

7. CONDUCTORS AND CABLES

Conductor and cables shall conform the provisions in Section 86-1.02F "Conductors and Cables and Section 87-1.03F "Conductors and Cable Installations".
Insulation for the conductors shall be type THW polyvinyl chloride.

Interconnect Cable (SIC) shall be Single Mode Fiber Optics (SMFO). The number and size shall be noted on the intersection drawing conductor schedule.

Jumping of signal commons from pedestrian signal mounting assembly terminal blocks to vehicle signal mounting assembly terminal blocks shall not be allowed.

The solid copper conductors terminating inside the controller cabinet shall have a #10 non-insulated fork lug, of the appropriate gauge size for the conductor, crimped and soldered to the conductor. Fork lugs for DLC and interconnect conductors shall be a #10 non-insulated fork lug gauge size "18-22" crimped and soldered to the conductor.

For existing traffic signals to be modified, and where existing conduits are to be reused at the direction of the Engineer:

Individual conductors shall be installed throughout the entire intersection. Use of multi-conductor cables shall not be allowed, except when used for temporary overhead wiring of signals.

A separate #12 AWG common from pedestrian signal mounting assembly terminal block and a separate #12 AWG common from vehicle signal mounting assembly terminal block shall be spliced to the #10 AWG signal common in the nearest adjacent pull box.

Banding of Conductors

For new traffic signals with multi-conductor cables, banding shall not be required. For all others:

Vehicle signal conductors shall have one band of PVC tape placed around the grouped red, yellow, brown, and #12 AWG common for each separate phase, in the nearest adjacent pull box with a conduit for the signal standard with a vehicle signal head(s) for that phase(s), and in the terminal compartment for each phase. Right turn and left turn overlap conductors shall have one band of PVC tape placed around the grouped yellow and brown conductors for each separate phase, in the nearest adjacent pull box with a conduit for the signal standard with the vehicle signal face(s) for that phase(s) and in the terminal compartment for each phase. In the event there are two or more phases and associated signal heads on a single standard, the #12 AWG common conductor for those signal heads shall only be banded to any one group of three signal conductors for any one phase in the pull box.

Vehicle signal heads located on mast arms shall be identified by placing bands of PVC tape around the grouped red, yellow, green, and common for each signal head. The signal head closest to the standard to which the mast arm is attached shall be identified with one band. The second closest signal head to the standard shall be identified with two bands, the third closest with three bands and so on.

Pedestrian signal conductors shall have one band of PVC tape placed around the grouped red, brown, and #12 AWG common for each separate phase in the nearest adjacent pull box with a conduit for the signal standard with a pedestrian signal head(s) for that phase(s) and in the terminal compartment for each phase. In the event there are two or more pedestrian phases and associated pedestrian signal heads on a single standard, the #12 AWG common conductor for those pedestrian signal heads shall only be banded to any one group of two pedestrian signal conductors for any one phase in the pull box.

Luminaire conductors shall have one band of PVC tape placed around the grouped #10 AWG black and white conductors in all pull boxes. In the nearest adjacent pull box with a conduit for the signal standard for which a luminaire has been installed on that standard the grouped #10 AWG black and white conductors shall have one band of PVC tape placed around each group of conductors being spliced together.

Signal commons shall be identified with one band of PVC tape in all pull boxes. In the nearest adjacent pull box with a conduit for the signal standard for which signal common

conductors have been spliced, one band of PVC tape shall be placed around each # 10 AWG and # 12 AWG signal common conductor being spliced together.

Pedestrian push button conductors shall not require any bands in any pull box.

Inside the controller cabinet all conductors shall be banded in separate groups of three for vehicle signals, two for pedestrian and overlap signals, and each pedestrian push button conductor shall be banded separately. Each group shall have the same number of bands corresponding to the associated phase, i.e., phase two shall have two bands; phase four shall have four bands, signal commons shall have one band, etc. The band for phase five shall be one band of PVC tape 2 inches or more in length.

Phases 6,7,and 8 shall have one long band for the number 5, plus1 band for phase 6, plus 2 bands for phase 7, and plus 3 bands for phase 8.

Overlap conductors shall have the same number of bands around each pair of conductors as the phase that it is associated with.

All PVC tape for banding of conductors, except detector lead-in cables and loop conductors, in all pull boxes, terminal block compartments, service enclosure, and the controller cabinet shall be black Scotch Super 33+ professional grade vinyl electrical tape. Substitutions of any other type of PVC tape shall not be used for banding.

Black tape shall not be used for identifying detector lead-in cables and/or loop conductors. Detector lead-in cables and loop conductors shall be banded in the pull box where spliced onto loops using colored tape only.

A Detector Lead-in Cable shall have the same color and number of bands on each end of the cable.

The colors for Detector Lead-in Cables shall be as follows:

1. North leg of the intersection shall be RED bands.
2. South leg of the intersection shall be WHITE bands.
3. East leg of the intersection shall be BLUE bands.
4. West leg of the intersection shall be ORANGE bands.

Loop Circuit Pairs shall be identified in each lane starting with the circuit pair (loop) closest to the stop bar or cross walk line by wrapping one band around the pair of conductors. The second circuit pair in the same lane shall have two bands wrapped around the pair of conductors. The third circuit pair in the same lane shall have three bands wrapped around the pair of conductors, and so on.

The color of the bands for the loop circuit pairs shall be as follows:

1. The first lane closest to the pull box in which the loops are spliced shall be identified with RED bands around the loop circuit pairs.

2. The second lane closest to the pull box in which the loops are spliced shall be identified with WHITE bands around the loop circuit pairs.
3. The third lane closest to the pull box in which the loops are spliced shall be identified with BLUE bands around the loop circuit pairs.
4. The fourth lane closest to the pull box in which the loops are spliced shall be identified with ORANGE bands around the loop circuit pairs.
5. Fifth, sixth, and seventh shall be green, yellow, and purple, respectively.

8. SPLICING

Splicing shall conform to the provisions of Section 86-1.02H “Splicing Materials” and Section 87-1.03H “Conductor and Cable Splices”.

All splices shall be soldered.

Conductors No. 8 AWG or larger, shall be spliced by the use of compression connectors and soldered.

All splices shall be insulated with 3 complete wraps of self-fusing, oil and flame-resistant, rubber-splicing tape, 3 complete wraps of Scotch Super 33+ professional grade vinyl electrical tape, and completely coated with 3M Scotchkote electrical coating extending a minimum of 1 inch past tape. All wraps of tape shall extend a minimum of 1 inch past conductor insulation. Substitutions of any other type of PVC tape in lieu of Scotch Super 33+ professional grade vinyl electrical tape shall not be used for splicing.

All splices shall be capable of satisfactory operation when subjected to continuous submersion under water.

Splicing will be permitted in the nearest adjacent pull box of a signal standard in lieu of looping conductors up and then down the signal standard.

Looping conductors up and then down a signal standard shall not be allowed.

9. STANDARDS, POLES, PEDESTALS, AND POSTS

Standards, steel pedestals, and posts shall conform to the provisions in Sections 86-1.02J and 87-1.03J “Standards, Poles, Pedestals and Posts”, of the State Standard Specifications and these Special Provisions.

Where the Plans refer to the side tendon detail at the end of the signal mast arm, the applicable tip tendon detail may be substituted.

In addition to identifying each pole shaft as detailed on ES-7M of the State Standard Plans, the manufacturer shall also identify each mast arm for all signals and luminaries. The

stamped metal identification tag shall be located on the underside of mast arm near the butt end and shall contain the same information required by ES-7M.

10. LUMINAIRES

Luminaires shall be Cooper Lighting Streetworks Model No. NVN-AE-03-E-U-SLL-10K-4-AP.

LED LUMINAIRES

A. Material and specifications for each luminaire are as follows:

1. Each Luminaire shall consist of an assembly that utilizes LEDs as the light source. In addition, a complete luminaire shall consist of a housing, LED array, surge module and electronic driver (power supply).
2. Each luminaire shall be rated for a minimum operational life of 50,000 hours at an average operating time of 11.5 hours per night at 40°C (104°F).
3. The rated operating temperature range shall be -30°C (-22°F) to +40°C (104°F).
4. Each luminaire is capable of operating above 104°F (40°C), but not expected to comply with photometric requirements at elevated temperatures.
5. Photometry must be compliant with IESNA LM-79.
6. Each luminaire shall meet all parameters of this specification throughout the minimum operational life when operated at the average nighttime temperature.
7. The individual LEDs shall be constructed such that a catastrophic loss or the failure of one LED will not result in the loss of the entire luminaire.
8. Luminaire shall be constructed such that LED modules may be replaced or repaired without replacement of whole luminaire.
9. Luminaire shall be constructed such that there is a replaceable door with the surge module and electronic drivers mounted to that door.
10. Each luminaires shall be listed with Underwriters Laboratory, Inc. under UL I 598 for luminaires.

B. Technical Requirements:

1. Electrical

- a. Luminaire shall have a minimum light output of 11,100 lumens and shall consume no more than 160 watts. The luminaire shall not consume power in the off state.
- b. Operation Voltage: The luminaire shall operate from a 60 HZ \pm 3 HZ AC line over a voltage ranging from 108 V AC to 305 VAC. The fluctuations of line voltage shall have no visible effect on the luminous output.
- c. Power Factor: The luminaire shall have a power factor of 0.9 or greater.
- d. THD: Total harmonic distortion (current and voltage) induced into an AC power line by a luminaire shall not exceed 20 percent.
- e. Surge Suppression: The luminaire onboard circuitry shall include surge protection devices (SPD) to withstand high repetition noise transients as a result of utility line switching, nearby lightning strikes, and other interference. The SPD protects the luminaire from damage and failure for common (Line-to-Ground) and differential (Line-to-Line) mode transient peak currents up to 10 kA (minimum). SPD must conform to UL 1449 requirements. SPD performance has been tested per procedures in ANSI/IEEE C62.41-2:2002 category C high exposure and ANSI C136.2 10kV BIL. The SPD shall fail in such a way as the Luminaire will no longer operate. The SPD shall be field replaceable.
- f. Operational Performance: The LED circuitry shall prevent visible flicker to the unaided eye over the voltage range specified above.
- g. RF Interference: LED Drivers must meet Class A emission limits referred in Federal Communications Commission (FCC) Title 47, Subpart B, Section 15 regulations concerning the emission of electronic noise.
- h. The individual LED module, the surge module and the electronic driver shall all be individually IP-66 rated.

2. Photometric Requirements

- a. Optical Assemblies: LEDs shall be provided with discreet over optical elements to provide an IESNA Type II distribution.
- b. Backlight Control (Bug Rating of B2-UO-G2): A specific backlight control method shall be utilized to mitigate light from direct LED source to achieve less than 22% of light behind the luminaire. Mitigation must take place without external shielding elements and by use of optical control only. Utilizing this optical control will greatly reduce obtrusive spill light behind the pole without reducing the efficiency of the fixture.
- c. All LEDs and optical assemblies shall be mounted parallel to the ground.

- d. All LEDs shall provide the same Type II optical pattern such that a catastrophic failure of individual LED will not constitute a loss in the distribution pattern. The light from each individual LED must render the entirety of the Type II pattern.
- e. No more than 2% of the total luminaire lumens shall be in the 80° to 90° range and no lumens will be emitted above 90°. BUG rating shall not exceed B2-UO-G2.
- f. Light Color/Quality: The luminaire shall have a correlated color temperature (CCT) of 4,000K +/- 275K. The color rendition index (CRI) shall be a nominal 70.
- g. Minimum of 75% of the total luminaire lumens shall be to the street side of the luminaire.
- h. The optical assembly of the luminaire shall be protected against dust and moisture intrusion per the requirements of IP-66 (minimum) to protect all optical components.
- i. Luminaire manufacturer shall provide the LED manufacturers LM-80 report.
 - i. LM-80 report shall be at a drive current of 1,000mA or less
 - ii. LM-80 report shall be a minimum of 10,000 hours
 - iii. LM-80 report shall show lumen depreciation of 1% or less for all LED case temperatures on the report including 55°C, 85°C, 105°C

3. Thermal Management

- a. The thermal management (of the heat generated by the LEDs) shall be of sufficient capacity to assure proper operation of the luminaire over the expected useful life.
- b. The LED manufacturer's maximum thermal pad temperature for the expected life shall not be exceeded.
- c. Thermal management shall be passive by design and include aluminum fins mounted to and directly above individual LEDs. The use of fans or other mechanical devices shall not be allowed.
- d. The luminaire shall have a minimum heat sink surface such that LED manufacturer's maximum junction temperature is not exceeded at maximum rated ambient temperature.
- e. The heat sink material shall be aluminum.

4. Physical and Mechanical Requirements

- a. Thermally conductive extruded aluminum heat sinks shall be secured to a clear anodized extruded aluminum door frame with a cast aluminum end cap for optimum cooling. The cast aluminum electrical compartment shall be separate from the LED array to ensure cooler operating temperatures of the driver. Access to the electrical compartment shall be tool-less by use of stainless steel latches. Driver and surge module shall be secured to the swing down door which can easily be removed and exchanged without the use of tools by separating a quick disconnect electrical connection. Housing shall be designed to prevent the buildup of water on the top of the housing. Each optical assembly shall be field rotatable and shall have "street side" and "house side" cast into the optics to indicate beam pattern. Each optic shall be electrically connected with a quick disconnect plug and secured to the housing with four stainless steel screws to enable easy optical replacement.
- b. Luminaire shall include cast in pipe stops, leveling steps and a four bolt mounting system capable of accommodating 1 1/4" to 2" ID pipe (1 5/8" to 2 3/8" OD).
- c. The maximum weight of the luminaire shall be 26 lbs and the maximum effective projected area shall not exceed 1.2.
- d. The housing shall meet the requirements for NEMA/UL wet location, be UL listed and grey in color with a flat or semi-gloss sheen.
- e. Luminaire shall include a NEMA photo control receptacle.
- f. The assembly and manufacturing process for the LED luminaire shall be designed to assure all internal components are adequately supported to withstand mechanical shock and vibration. Luminaire shall withstand vibration, meeting ANSI C136.31 American Standard for Roadway and Area Lighting Equipment - Luminaire Vibration for normal and bridge operation (3G minimum).

5. Materials

- a. Housing and door frame shall be aluminum with a nominal 2.5 mil thick paint finish able to withstand a 3000-hour salt spray test as specified in ASTM Designation: B 117.
- b. Each refractor or lens shall be made from UV inhibited high impact optical grade material and be resistant to scratching.

C. INSTALLATION

1. Installation and configuration shall conform to the requirements of the NFPA 70 (National Electrical Code), and applicable local codes.
2. Installation shall conform to manufactures recommended instructions.

D. WARRANTY

Manufacturer shall warrant to the original purchaser that the factory-installed electrical system will be free from defects in material and workmanship for 5 years from the date of shipment of the products. If 10% of the individual LEDs (light sources) should fail within 5 years of shipment, manufacturer will, at its sole option, ship a repaired or replacement fixture.

11. SERVICE ENCLOSURE

The service enclosure shall conform to the Sections 86-1.02P(2) and 87-1.03P “Service Equipment Enclosures” and the Standard Plan ES-2C.

The service enclosure shall be model P28-105-A, manufactured and furnished by Tesco Controls Inc. The service enclosure shall be the Type III-BF. The enclosure shall be anodized aluminum and all exterior seams shall be continuously welded. Over-lapping seams shall be sealed with a neoprene gasket and meet NEMA 4 requirements. Pressure welds (spot welding) shall not be used to fabricate the enclosure. Rivets shall only be used to attach nameplates. Use of rivets to attach any other components of the enclosure shall not be allowed. All rivets shall be stainless steel or aluminum.

Hinges shall be aluminum or stainless steel with a stainless steel hinge pin. The hinges shall be bolted to the enclosure. The hinge pins and bolts shall not be accessible when the door and/or hood are closed.

The door, meter reading cover door, photo cell window, and line access cover panel shall have the entire inside perimeter of the door, panel, etc, lined with a neoprene gasket. All neoprene gaskets shall be permanently bonded to the aluminum.

All bolts, washers, nuts, screws, hinge pins, and door latch assembly parts used to fabricate the service enclosure shall be Type 316 stainless steel. The enclosure shall be rain-tight and dust-tight. See exhibit “A” for wiring diagram and further details.

12. CONTROLLER ASSEMBLIES

The controller assembly shall conform to Sections 86-1.02Q and 87-1.03Q “Cabinets”, the “Transportation Electrical Equipment Specifications” (TEES), and the “Traffic Signal Control Equipment Specifications” (TSCES).

The controller assembly shall be manufactured and furnished by McCain Traffic Supply.

The controller shall be model 170E-ATC-COLDFIRE-LCD, Software Application 750 (1)

The controller cabinet shall be a 332-A anodized aluminum enclosure, (TSCES) Type 1 housing, with a PDA2 combination power supply / power distribution assembly.

The conflict monitor shall be model 210. (1)

Red monitoring circuits shall not be installed in the load bay.

The load switches shall be model 200. (12)

The flashers shall be model 204. (2)

The loop detectors shall be model 222. (16)

The D.C. isolators shall be model 242. (3)

The flash transfer relays shall be model 430. (4)

The modem shall be model 400, 1200-baud rate (1)

The controller cabinet door locks shall be “Best” brand and be keyed for the “R” type key.

The controller cabinet air filter shall be the 4-ply woven polypropylene type.

The controller cabinet shall be equipped with (2) fluorescent lighting fixtures mounted to the fan housing, parallel to the door openings. The front lamp housing shall be mounted 2-1/2 inches from inside wall of the cabinet to the center of the lamp housing. The rear lamp housing shall be mounted 7 inches from inside wall of the cabinet to the center of the lamp housing.

The thermostat assembly shall be mounted on the fan housing in the middle of the cabinet with the thermostat control dial facing the rear of the cabinet.

All exterior seams shall be continuously welded.) This shall include the seams at the bottom of the cabinet where the cabinet walls join the cabinet base plate. The seams shall be continuously welded on the outside bottom of the cabinet. This will prevent unwanted dirt, water, and insects from entering the cabinet through the bottom seam.

The cabinet shall be rain-tight and dust-tight.

All traffic control equipment to be furnished shall be currently listed on the Department of Transportation qualified products list.

All necessary auxiliary equipment shall be supplied with the controller assembly to control the system as shown on the plans, and as specified in the state specifications and these special provisions.

The contractor shall construct the 12 inch raised controller cabinet foundation including furnishing and installing the anchor bolts (see the section on foundations earlier in these provisions), and if necessary a surrounding pad as shown on Standard Plan ES-3C. The contractor shall place a solid 1/2 to 3/4 inch diameter bead of acrylic latex caulk around the entire perimeter of the foundation, (2) inches in from the edge of the cabinet walls, and install

the controller cabinet on the foundation. The contractor shall make all field wiring connections inside the controller cabinet. Caulking around the outside perimeter of the cabinet base will not be required.

The contractor shall arrange to have a qualified signal technician employed by the controller manufacturer, or their representative, present at the time the signal system is turned on.

13. VEHICLE SIGNALS

All signal faces, sections, heads, back plates, visors and fittings shall conform to Section 86-1.02R and Section 87-1.03R "Signal Heads", and the California Department of Transportation Revised Standard Plans section RSP ES-4C.

All signal faces shall be 12-inch (300mm) and shall have full circle visors.

All signal faces and housings shall be polycarbonate plastic.

All polycarbonate plastic vehicle signal heads shall have plastic back plates and plastic visors flat or dull black in color and shall meet the requirements of Sections 86-1.02R(3) and 87-1.03R(3) of the State Standard Specifications. Type 316 stainless steel screws and washers shall be placed in all back plate mounting screw holes on all vehicle signal heads.

All vehicle signal faces shall utilize Dialight, Electro-Tech's, or GELcore LED modules for all colors. All LED modules shall conform to Section 86-1.02R(4)(b).

All signal heads shall be sealed with a flat metal washer and neoprene gasket installed on the lock nipple inside the top signal section in contact with the serrated elbow fitting of the mounting assembly.

All screws, bolts, washers, nuts, door hinge pins, door latching assemblies, etc. inside and outside of the all signal heads shall be Type 316 stainless steel.

14. PEDESTRIAN SIGNALS

All pedestrian signal faces and housings shall conform to Section 86-1.02S and Section 87-1.03S "Pedestrian Signal Heads.

All front screens for pedestrian signal faces shall be the Z-crate Type per Section 86-1.02S(3)(d).

The lens door/frame shall be a one-piece screen-door combination made of black polycarbonate plastic, flat or dull black in color.

The housing shall be Type "C" made of polycarbonate plastic, flat or dull black in color.

All pedestrian signal housings shall have a round opening in the top and bottom of the housing to receive a 1.5-inch diameter lock nipple.

The top and bottom openings of all pedestrian housings shall have serrations capable of being locked at 5-degree intervals to the top and bottom serrated elbow fittings of the mounting assembly

The top opening of all pedestrian signal housings shall be sealed with a flat metal washer and neoprene gasket installed on the lock nipple inside the top portion of the pedestrian signal housing in contact with the serrated elbow fitting of the mounting assembly.

All pedestrian signal faces shall utilize Dialight, or GELcore countdown LED modules. All LED modules shall conform to Section 86-1.02S(3)(c) and shall be the countdown type.

All screws, bolts, washers, nuts, door hinge pins, door latching assemblies, etc. inside and outside of the pedestrian signal heads shall be Type 316 stainless steel.

Signal Mounting Assemblies

All signal mounting assemblies shall conform to Section 86-1.02R(2) and 87-1.03R(4) "Signal Mounting Assemblies", 86-1.02S(2) "Pedestrian Signal Mounting Assemblies: ", and the State Revised Standard Plans RSP ES-4A, RSP ES-4B, RSP ES-4C, ES-4D, and RSP ES-4E.

All pipes and fittings used to fabricate signal-mounting assemblies shall be galvanized steel.

All elbow fittings in contact with any signal head section and/or any pedestrian housing opening shall have serrations to match the serrations on the signal head sections and/or pedestrian housing openings, top and bottom.

All signal heads, vehicle and pedestrian, shall be sealed with a flat metal washer and neoprene gasket installed on the lock nipple inside the top signal section and/or pedestrian housing opening in contact with the serrated elbow fitting of the mounting assembly.

All mast arm slip-fitter plumbizers shall be the MAS type. MAT type slip-fitter plumbizers shall not be used.

The MAS plumbizer shall be adjusted so that the vertical axis of the signal head is plumb and the horizontal axis of the signal head is level.

All setscrews, (mast arm plumbizer securing bolts, nuts, and washers), terminal block screws, and terminal compartment door screws for all mounting assemblies shall be Type 316 stainless steel. All mounting assemblies shall be painted dull or flat black in color.

15. PEDESTRIAN PUSH BUTTONS

Pedestrian push button housings shall be Type B, and shall conform to Section 86-1.02U and 87-1.03U “Push Button Assemblies” and the “Americans with Disability Act” requirements. Pedestrian push button housings shall be either die-cast or permanent mold-cast aluminum.

Pedestrian push button signs shall be porcelain enameled metal. The sign legend shall be a symbolic person and arrow (black) on white background.

All push button housing mounting bolts, sign mounting screws, and push button cap screws shall be Type 316 stainless steel. Sign mounting screws shall not be the theft-proof type.

All pedestrian push button housings and push button caps shall be painted black in color.

16. INDUCTIVE LOOPS

Six-foot diameter Type E circular loops and Type D bicycle/motorcycle loops shall be installed per the plans. The sides of the slot shall be vertical. The depth of the loop slot shall be 2.5 inches. The slot for the “home runs” shall be 3/8 of an inch wide and shall be at the same depth (2.5 inches) when entering the loop. The “home run” slot when entering the loop shall be such that both sides of the slot shall be at an angle greater than 90 degrees in relation to the outside portion of the loop. The depth of the “home run” slot when entering the loop stub out conduit area shall be a minimum of (3.5 inches). The bottom of the saw cut slot shall be smooth, with no sharp edges, and at a consistent depth throughout the saw cut. The last 5 feet of the home run slot shall, incrementally and consistently, increase in depth from (2.5 inches) to a minimum of (3.5 inches) at the loop stub out conduit.

Conduit for all loop “stub outs” shall be 2-inch schedule 40 PVC. The end of the loop “stub out” conduit in the roadway shall be 5” below the surface of the roadway.

After all loop wires have been installed, the stub out shall be sealed with an approved type of sealing compound. The stub out hole shall be filled with a layer of fine sand to 3” below the road surface, and the remaining portion of the hole shall be filled with cold-patch asphalt, which when compacted shall be flush with the surrounding pavement surface.

All saw cut slots shall be filled with Hot-Melt Sealant.

Twisting of the loop conductors shall not be required.

Residue resulting from slot cutting operations shall not be permitted to flow across shoulders or lanes occupied by public traffic and shall be removed from the pavement surface.

Loops shall be centered in the lanes and shall be spaced 9 feet apart, (15 feet center of loop to center of loop). The (#1) loop in each lane shall be located directly behind the stop bar or crosswalk line. The saw cut slot of the loop shall not enter into any portion of the stop bar or crosswalk line.

Loop wire for circular loops shall be Type 2. The ends of the Type 2 loop conductors shall be insulated so as to prevent moisture from entering the plastic tubing.

Loop detector lead-in cable shall be Type B and be insulated so as to prevent moisture from entering the conductor jacket.

If any existing loop conductor, including the portion leading to the detector handhold or termination pull box, is damaged by the contractor's operations, the contractor shall immediately notify the Engineer. The damage shall be repaired at the contractor's expense and as directed by the Engineer within 24 hours. If the contractor fails to complete the repairs within this period, city forces at the contractor's expense will make the repairs.

17. EMERGENCY VEHICLE DETECTION

The emergency vehicle detection equipment shall be the G.P.S. type manufactured by Emtrac Systems. The equipment to be installed for the operation of the traffic signals shall be:

One (1) Emtrac Omni – Directional Antenna

One (1) Emtrac Priority Detector (ST-9078)

One (1) flexible coax cable (Belden RF195) 50-ohm from the Emtrac Omni – Directional Antenna to the Emtrac Priority Detector in the cabinet. Two (2) connectors for the coax cable shall be the solder-type BNC, (RF Industries RFB-1107-1X). The coax cable shall be (Belden RF195) 50-ohm. All excess cable in the controller cabinet shall be cut off and not be coiled in the cabinet.

One (1) copy of the Emtrac Systems Manager software & operations manual shall be supplied with each system.

A qualified Emtrac Systems technician shall perform the initial programming and testing of the Emtrac Priority Detector and Emtrac Omni – Directional Antenna at each intersection after installation.

Installation of the Emtrac Omni-Directional Antenna shall be on the top traffic signal controller cabinet, nearest the center of the intersection. 1 3/4" hole shall be drilled in the cabinet for the coax cable, and shall be made water-tight.

Please refer to the Emtrac Priority Control System Intersection Installation manual for more detailed installation instructions before installation.

18. BATTERY BACK-UP SYSTEM

A. General

The battery back-up system (BBS) shall be designed for Type 170/2070 traffic signal systems using LED traffic signal indications. The BBS shall be designed for outdoor applications, in accordance with Cal-Trans Transportation Electrical Equipment Specifications (TEES), dated August 16, 2002, (Chapter 1, section 8) requirements. The BBS shall provide reliable emergency power to a traffic signal system (Vehicle and Pedestrian Traffic) in the event of a power failure or interruption.

The BBS shall be capable of providing power for full operation for a “LED-only” intersection (all colors red, yellow, green and pedestrian heads), and/or a flashing mode operation.

The BBS shall provide a minimum two (2) hours of full run-time operation (minimum 700W/1000VA active output capacity, with 80% minimum inverter efficiency) for an “LED-only” intersection.

Whenever the batteries approach approximately 40% of remaining useful capacity, the BBS shall cause the intersection to revert to a flashing mode operation.

All necessary equipment (cabinet, inverter, switches, relays, batteries, battery cable harness, etc.) shall be included in the bid price of the BBS.

B. Specifications

The BBS shall be manufactured by Alpha Technologies, and shall consist of an inverter (part # FXM 1100) and all appurtenances necessary for a complete and operational system.

The entire system, including batteries shall be contained in an external cabinet (McCain part # M34196) made of stainless steel or anodized aluminum attached to the existing controller cabinet. Cabinets shall be equipped with a thermostatically controlled fan and terminal block for wire connections to fan unit.

The batteries shall be 79 AH, Gel Cell, Group 24 type. After installation, the battery posts, cable connectors, and exposed cable wire shall be covered with a generous coating of an approved liquefied anti-corrosion sealant.

All wiring provided between the combined Manual Bypass Switch / 30A Automatic Transfer Relay and cabinet terminal service block shall be #10 AWG. Relay contact wiring provided for the “Low Batt-Relay B” (NO / C) terminals shall be #18 AWG.

The manufacturer shall include two (2) sets of equipment lists, operation and maintenance manuals, and schematic and wiring diagrams of the BBS, and the battery data sheets. The manual shall conform to TEES August 16, 2002, Chapter 1 Section 1.2.4.

C. Warranty

The manufacturer shall provide a two (2) year factory-repair warranty for parts and labor on the BBS from date of acceptance by the city. The batteries shall be warranted for full replacement for two (2) years from date of purchase. The warranty shall be included in the total bid price of the BBS.

19. SIGNS

Traffic signs to be mounted on traffic signal standards and mast arms shall be furnished by the contractor. Sign panels shall be constructed of reflective sheeting on aluminum. Signs located on traffic signal standards and mast arms shall conform to the City of Oxnard Standard Plans Plate 206 or as specified on the plans.

The contractor shall furnish a certificate of compliance from the manufacturer showing that the sign panels conform to the specifications issued by the State of California, Department of Transportation, and/or the City of Oxnard for materials, size, and legend.

20. RECTANGULAR RAPID FLASHING BEACON

The Rectangular Rapid Flashing Beacon (RRFB) solar system shall be manufactured by TAPCO. The Rectangular Rapid Flashing Beacon (RRFB) Crosswalk Lighting System shall be fully compliant with all FHWA and MUTCD guidelines. The system shall consist of the following components:

A. System Server

The system server shall be housed in one or more independent facilities with on-premises 24/7 security staff and Uninterruptible Power Supply (UPS)

B. Controller

The controller shall be equipped with a GPRS/EDGE modem and GPS receiver attached to its antenna unit, and the system shall not require the installation or alteration of any other equipment or associated hardware, such as traffic signal controllers, Ethernet connections, local radios, local wireless connections or local networks.

The controller shall be housed in a vandal-resistant, fiberglass NEMA 4X pole-mounted cabinet with a lockable, hinged door, intended for indoor or outdoor use, primarily to provide a degree of protection against corrosion, windblown dust and rain, splashing water, hose-directed water, and damage from ice formation.

The LED light outputs and flash pattern shall be completely programmable, with the capability to actuate RRFB and LED-enhanced signs.

The controller shall be reconfigurable if future MUTCD or State guidelines specify a different flash pattern.

The controller shall be capable of storing input count data in preset intervals, with downloadable capabilities using Windows-based PC software program and standard programming cable.

The controller shall be, in the unlikely event of failure, replaceable independently of other components.

C. Rectangular Rapid Flashing Beacon (RRFB)

The RRFB shall be high performance (HP) RRFB. The RRFB housing shall contain two primary light bars mounted in compliance with MUTCD requirements, but exceeding the minimum 5"W x 2"H size and MUTCD total light emission requirements. In addition to the primary light bars, the housing shall have smaller secondary light bars mounted on each end for pedestrian notification, arrayed in a 0.4" W x 2"H rectangle. The secondary light bars shall have optional opaque covers if pedestrian notification from either or both ends of the housing is not desired. The overall dimensions of the RRFB unit shall be 29"W x 4"H x 1.5"D. The LEDs used in both the primary and secondary light bars shall be rated for a minimum 15 - year life, and the light bars shall not protrude beyond the surface of the housing, shall not be mounted to the housing with exposed screws, and shall be covered with polycarbonate windows for durability and vandal resistance. The RRFB shall draw attention at distances greater than 1000 feet during the day and over 1 mile at night.

The RRFB housing shall be made of powder-coated aluminum with a minimum thickness of 0.125", and shall provide a mounting mechanism allowing for directional rotation of the primary light bars toward oncoming traffic at curves, corners, and roundabouts.

The controller shall adjust RRFB brightness as outside light levels change between day and night, being brighter during the day and less bright at night. RRFB bars mounted on a pole shall be able to be independently aimed to optimize performance in each direction.

For each approach where the RRFB will be installed, W11-2 warning sign and W16-7p Arrow sign shall be installed on the same pole. W11-2 sign shall be a minimum size of 30"x30", and the W16-7p sign shall be a minimum of 24"x12".

D. Activation Devices

The controller shall be activated by an ADA compliant Polara Bulldog push button. A Pedestrian pushbutton instruction sign shall be furnished at a minimum size of 5"x7" and mounted adjacent to or integral with each pedestrian pushbutton.

E. Communication Protocols

Each controller shall be equipped with a GPRS/EDGE modem and GPS receiver attached to its antenna unit.

For security and reliability purposes, communication between the System Server and the Controller shall utilize the closed-loop Transmission Control Protocol/ Internet Protocol ("TCP/IP") over a highly secure Virtual Private Network ("VPN") in addition to the intrinsic security provided by the cell network encryption. Communication between the System Server and any desktop, netbook, tablet or smartphone running a mainstream browser, such as Internet Explorer, Firefox, Chrome or Safari ("Capable Device"), shall be via a secure (https) website and shall also use TCP/IP protocol, in this case encrypted using the same machinery employed in electronic funds transfer.

F. Wireless Transceiver Radio

Radio control shall be solar-powered, operating on a FCC- approved 900mhz frequency, hopping spread spectrum network with a normal operating range of 1000 feet.

Radios shall provide wireless communication between the assemblies to integrate the pushbutton activation of indications.

To ensure all integral indications consistently flash in unison, the Radio shall synchronize the controllers to activate the indications within 120msec of one other and remain synchronized throughout the duration of the flashing cycle.

Radio systems shall operate from 3.6 VDC to 15 VDC

The Radio shall be, in the unlikely event of failure, replaceable independently of other components.

The Radio shall have a minimum operating temperature range of -30dF to 165dF.

G. No Local Software

No local host or client software and its associated maintenance updates shall be required.

H. Remote Management

The controller shall be remotely managed for purposes of activation duration setting and maintenance. Remote management shall be performed over a cellular M2M network and the internet, from anywhere an internet connection can be made by a capable device. Multiple users from any locations with internet access shall be able to perform system management operations simultaneously.

I. Intuitive User Interface

Using unique user names and passwords, users shall be able to access the graphical, browser-based user interface ("UI").

For ease of system management, the UI shall use intuitive graphics, and the UI shall display an icon representing each Controller with its name and exact location on a Google Map.

Security access shall be hierarchical, and allow system administrators to assign system administrator, scheduler / editor or viewer-only permission to individual users.

J. Reports

Each system shall provide daily activation, bulb outage, battery health (solar only) and communication interruption (knockdown) reports through the UI. These reports may be viewed and/or downloaded.

K. Proactive Diagnostics

Each system shall generate proactive daily bulb outage, battery health (solar only) and communication interruption (knockdown) diagnostics delivered by email to a configurable set of recipients.

L. Mechanical and Electrical Specifications

Power Options:

The controller unit shall be available in a solar 12 VDC, 20 AHr version equipped with a 20W or 45W solar panel, as well as a 120 VAC, 50W version. Solar-powered system shall provide a minimum of 30 days of back-up battery power in the absence of sunlight while operating at full brightness and at standard usage levels.

The solar panel's battery shall be replaceable independently of other components.

M. Pedestal base & Pole Shaft

The RRFB system shall be mounted on standard 4.5" OD aluminum pedestal pole and signal pedestal base. Pole shall be an extruded seamless Aluminum 6061-T6 Schedule 40 manufactured, conforming to ASTM B 429. Pedestal base shall be aluminum casting made of 319 aluminum alloy. Base shall be threaded to receive a 4" NPT pedestal pole. Base shall include a door opening of minimum of 8.5" square and shall include an aluminum door attached with a stainless steel bolt.

N. Warranty

The controller unit and the HP RRFB Crosswalk Lighting System shall be supported by a three (3) year warranty.

21. TESTING

The functional test for each lighting system shall consist of not less than 7 days. If unsatisfactory performance of the system develops, the conditions shall be corrected and the test shall be repeated until the 14 days of continuous, satisfactory operation is obtained.

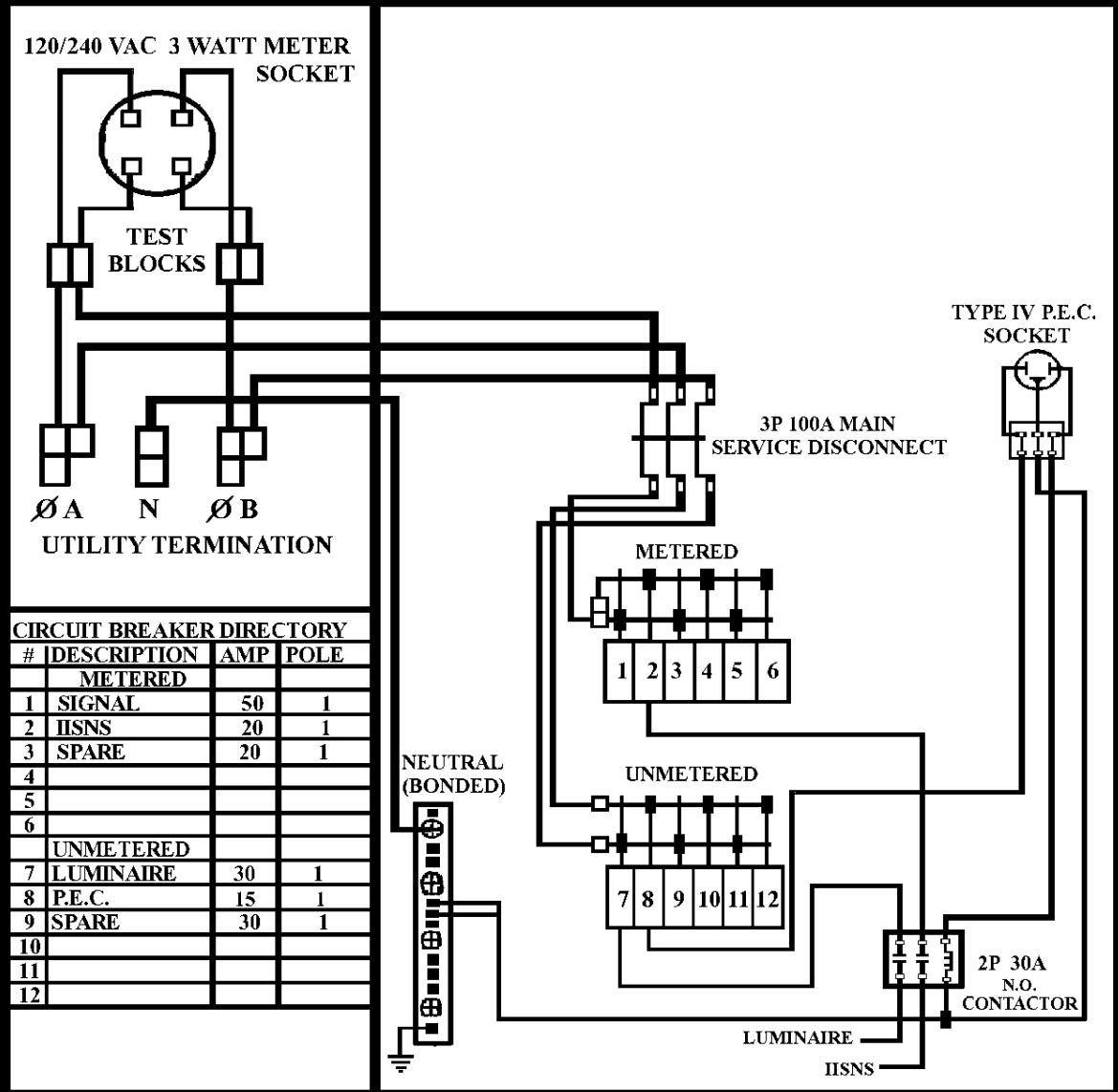

EXHIBIT " A "

WIRING DIAGRAM

TYPE III - BF SERVICE ENCLOSURE

120/240 VAC-SINGLE PHASE SECONDARY-100 AMPS MAXIMUM



CIRCUIT BREAKER DIRECTORY			
#	DESCRIPTION	AMP	POLE
METERED			
1	SIGNAL	50	1
2	IISNS	20	1
3	SPARE	20	1
4			
5			
6			
UNMETERED			
7	LUMINAIRE	30	1
8	P.E.C.	15	1
9	SPARE	30	1
10			
11			
12			

THE P.E.C. UNIT SHALL BE LOCATED IN THE LOWER HALF (LOAD AREA) OF THE ENCLOSURE. A TEST SWITCH FOR THE P.E.C. SHALL NOT BE INSTALLED. THE P.E.U. SHALL BE THE "TIME DELAY" TYPE AND SHALL NOT BE SHIELDED. THE ENCLOSURE SHALL CONFORM TO THE STATE OF CALIFORNIA STANDARD SPECIFICATIONS (JULY 2002) SECTION 86-2.11, THE STATE OF CALIFORNIA STANDARD PLANS, JULY 2002 SECTION ES-2C, AND THE ATTACHED CITY OF OXNARD SPECIAL PROVISIONS. A BASE, COMPLETE WITH FOUNDATION BOLTS, NUTS, WASHERS AND MOUNTING BOLTS AND WASHERS, SHALL BE INCLUDED WITH EACH ENCLOSURE. ALL EXTERIOR SEAMS OF THE ENCLOSURE SHALL BE CONTINUOUSLY WELDED PRESSURE (SPOT) WELDING SHALL NOT BE ALLOWED FOR CONSTRUCTION OF THE ENCLOSURE.