

RECEIVED
MAR 09 2007
PLANNING DIVISION
CITY OF OXNARD

Exhibit "A"

2330 SAVIERS ROAD
CITY OF OXNARD, CA

SIGN CRITERIA

LESSOR
NAME OF LESSOR.

CAL ASIA PROPERTY DEVELOPMENT

CAL-ASIA PROPERTY DEVELOPMENT CENTER SIGN PROGRAM

Date: May 9, 2007

I. INTRODUCTION

- A. **INTENT:** Intent of these sign criteria is to provide the guidelines necessary to achieve a visually coordinated, balanced and appealing signage environment at **2330 Saviers Road.**
- B. **REMOVAL OF NONCONFORMING SIGNS:** The Lessee or its sign contractor at their expense, upon demand by Lessor, shall remove any non-conforming signs. The local governing jurisdiction-planning department shall utilize these criteria in review and approval of proposed signs.
- C. **APPROVAL OF SIGN AUTHORITY:** The Lessor, through its representative, will retain full rights of approval of any sign used in the center in consultation with the local governing jurisdiction-planning department. In no case; however, shall the proposed sign violate any provision of the governing jurisdictions ordinances.
- D. Exceptions to these standards shall be reviewed by the Lessor and its representative. However, in order to maintain the integrity of the criteria and equity of the sign criteria among tenants, deviations will not generally be approved. Accordingly, the Lessor, through its representative, will retain full rights of approval of any sign used in the center in consultation with the local governing jurisdiction planning department. In no case however, shall the proposed sign violate any provision of the governing jurisdictions ordinances. Signs that do not conform to the criteria set here may be required by the local planning department to go through a more extensive design review process, which may delay the issuance of the sign permit.

II. GENERAL OWNER/TENANT REQUIREMENTS

- A. Each tenant shall submit to the Lessor's representative for written approval, five (5) copies of the detailed shop drawings of his proposed sign, indicating the location, size, layout, design and color of the proposed signs, including all lettering or graphics in conformance with the sign criteria herein outlined. Requests for approval shall be submitted to:

T. W. Layman Associates
16633 Ventura Blvd., Suite 1320

Lessor Initial: _____

Lessee Initial: _____

Encino, CA 91436

1. The plans to be submitted to the Lessor shall, as a minimum, include the following:
 - a) A site plan illustrating the leased premises on the site.
 - b) An elevation of the leased premises drawn to scale and showing sign placement and the location of the demising walls.
 - c) A detailed elevation of the sign, drawn to scale, and specifying all colors, materials, dimensions and copy.
 - d) Fabrication and installation details, including structural and engineering data, "UL" electrical specifications and type and intensity of illumination for electrically lit signs.
 - e) Any other drawings, details and information required of the applicable governmental agencies as a condition of a permit for construction and installation.
 - f) All plans shall be 8 ½"x11" and colored.
- B. The Lessee shall submit the sign drawing approved by the Lessor or its representative to the appropriate local governing jurisdiction authority for approval prior to the start of any sign construction.
- C. The Lessee shall pay for all signs, their installations (including final connecting transformers and all other labor and materials), the cost of all governmental agency approvals and all maintenance.
- D. The Lessee shall obtain all necessary governmental agency approvals and permits and shall insure that all signs and the installation thereof complies with all applicable zoning, building and electrical codes.
- E. The Lessee shall be responsible for fulfillment of all requirements of these sign criteria.
- F. The Lessor shall provide a single electrical service termination at the center of the allowed signage area as follows:
 1. Sign Cabinets: Exterior of wall or canopy
 2. Individual Letter Cans: Interior of wall or canopy
- G. It is the responsibility of the Lessee's sign company to verify all conduit and transformer locations and service prior to fabrication.
- H. The location of all signs shall be per the accompanying design criteria.
- I. One "sign space" shall be allowed for each in-line tenant or as otherwise approved in writing and consistent with the local governing jurisdiction's ordinances.

Lessee shall verify its sign location and size with Lessor prior to commencing fabrication drawings.

- J. Address numbers shall be applied to the each store by the Lessee's sign company during regular course of construction pursuant to local governing ordinances (but in no event less than 5" high white Arabic numerals) at the front of the business centered above the primary entrance), and the rear of the building if public access is available.
- K. The maximum allocated sign area shall be the aggregate of all permanent signs (except exempt and convenience signs) as noted in Section III, D-5.
- L. Signs to be used at this center are individual channel letters only unless otherwise approved by the Lessor.
- M. Lessee shall erect their signage on the storefront fascia not later than the date Lessee opens for business.

III. GENERAL SIGN SPECIFICATIONS

- A. No exposed raceway, crossovers, conduits, conductors, transformers, lamps etc. shall be permitted.
- B. All lettering shall be restricted to the "net sign area" as follows:
 - 1. Wall Signs
 - (1) Sign Location: The main business identification sign shall be centered on the building fascia, both vertically and horizontally. The Lessor shall approve the placement of secondary signs. See also exhibit "B."
 - (2) Sign Area: The total maximum aggregate sign area shall not exceed Two (2.0) square foot of sign area for each lineal foot of building on the principal street or one square foot of sign area for each lineal foot of lot frontage on the principal street, whichever is larger, provided that the maximum sign area for any individual business shall be 1,200 square feet. Individual sign area not to exceed 50 sq. ft. per sign.
 - (3) Sign Height: The signage format shall not exceed thirty inches (36") in height for the primary sign.
 - (4) Sign Width: The sign width shall not exceed dimensions shown on exhibit "B".

- (5) Sign Projection: The sign shall not project more than 8" from the face of the building, see exhibit "B."
 - (6) Sign Color: Lessee corporate colors are allowed.
 - (7) Logos: Logos (fully dimensioned) shall be located within the "net sign area" and are subject to approval of the Lessor.
2. All signs and their installation must comply with all local zoning, building and electrical codes.
 3. For purposes of store identification, Lessee will be permitted to place upon each entrance to its demised premise not more than 144 square inches of gold leaf or decal application lettering not to exceed two inches (2") in height, indicating hours of business, emergency telephone, etc. The number and letter typeface shall be subject to the Lessor's representative's approval.
 4. Delivery Signs: Delivery entrance signs on the rear of Lessee's premises may be installed consisting of 2" high Helvetica medium letters identifying the business name and address on a non-customer delivery entrance. The location of this sign shall be subject to Lessor approval and shall not exceed four (4) square feet in area.
- C. Typically Internally Illuminated, Individual & Letter Sign Specifications:
1. Lessee signs shall be attached in designated areas only and may not exceed the net sign area noted herein, or the limits set forth in the local governing jurisdiction zoning code, except as same may be amended by exception and/or variance, whichever is more restrictive.
 2. The face of the individual letters and logos shall be constructed of acrylic plastic (3/16" thick minimum), and fastened to the channeled metal can in an approved manner. Acrylic retainers used at the perimeter of sign letter faces shall match in color and finish the face of the sides of the signs.
 3. The "Copy" (letter type), logos, and their respective colors shall be submitted to the Lessor's representative for written approval prior to fabrication.
 4. No more than two rows of letters are permitted, provided their maximum total height does not exceed the height of the "net sign area".
 5. Lessees shall display only their established trade name or their basic product name, e.g., "John's Jeans", or combination thereof.
 6. Internal illumination shall be 30-milli amps. neon, installed and labeled in accordance with "National Board of Fire Underwriters Specifications".

7. Color of exposed portions of sign can and frame shall paint to match the color of the building or the corporate color.

D. Center Monument Sign

1. Sign Dimensions: See Exhibit "C"
 - a) Base of sign shall maintain a solid base at least six (6) inches in height.
2. Sign shall be placed within a landscaped planter area.
3. Sign structures shall match the architectural design and color of the building(s).
4. Sign specifications must include:
 - a) Sign construction
 - b) Double face fabrication
 - c) Base fabrication
 - d) Internally Illuminated
5. Sign area shall not exceed a total sign area of 50 square feet.
6. Sign height shall not exceed 42" in height.

IV. PROHIBITED SIGNS

A. Signs Constituting a Traffic Hazard:

1. No person shall install or maintain or cause to be installed or maintained any sign which simulates or imitates in size or color, lettering or design of any traffic sign or signal, or which makes use of the words "STOP", "LOOK", "DANGER" or any other words, phrases, symbols, or characters in such a manner to interfere with, mislead or confuse traffic.

B. Immoral or Unlawful Advertising:

1. It shall be unlawful for any person to exhibit, post, or display cause to be exhibited, posted or displayed upon any sign, anything of obscene, indecent or immoral nature or unlawful activity.

C. Signs on Doors, Windows or Fire Escapes:

1. No window signs will be permitted except as noted herein. No sign shall be installed, relocated or maintained so as to prevent free ingress to or egress from any door.

2. No sign of any kind shall be attached to a standpipe except those signs as required by code or ordinance.
- D. Animated, Audible, or Moving Signs:
1. Signs, consisting of any moving, swinging, rotating, flashing, blinking, scintillating, fluctuating or otherwise animated light are prohibited, except for time and temperature displays.
- E. Off-Premise Signs:
1. Any sign, other than a directional sign, installed for the purpose of advertising a project, event, person or subject not related to the premises upon which said sign is located, is prohibited.
- F. Vehicle Signs:
1. Signs on or affixed to trucks, automobiles, trailers or other vehicles, which advertise, identify, or provide direction to a use or activity not related to its lawful making of deliveries of sales of merchandise or rendering of service from such vehicles, is prohibited.
- G. Light Bulb Strings and Exposed Tubing:
1. External displays, other than temporary decorative holiday lighting, which consist of unshielded light bulbs, and open, exposed neon or gaseous light tubing, are prohibited.
 2. The Lessor's representative hereto may grant an exception when the display is an integral part of the design character of the activity to which it relates.
-
- H. Banners, Flags, Pennants, and Balloons Used for Advertising Purposes:
1. Flags, banners or pennants, or a combination of same, constituting an architectural feature which is an integral part of the design character of a project may be permitted subject to Lessor's representative and local governing jurisdiction approval, and shall not be erected in violation of the local governing jurisdiction's ordinances regulating signs.
- I. Signs in Proximity to Utility Lines:
1. Signs, which have less horizontal or vertical clearance from authorized communication or energized electrical power lines than that prescribed by the laws of the State of California are prohibited.
- J. Painted Signs:
1. Lettering painted directly on a building or other material, which is then attached to a building, will not be permitted except as noted herein.
- K. Those signs prohibited by the local governing jurisdiction's ordinances.

- L. No signs allowed on canopies.

V. CONSTRUCTION REQUIREMENTS

- A. All exterior signs, bolts, fasteners, and clips shall be of enameling iron with porcelain enamel finish, stainless, steel, aluminum, brass or bronze. No black iron materials of any type will be permitted.
- B. Interior signs only may be fabricated of carbon bearing steel with painted finish.
- C. All exterior letters or signs exposed to the weather shall be mounted at least three quarters of an inch (3/4") and no more than one and one half inch (1½") from the building wall to permit proper dirt and water drainage.
- D. All letters shall be fabricated using full welded construction.
- E. Locations of all openings for conduit and sleeves in sign installation shall be neatly sealed in a watertight condition.
- F. No labels will be permitted on the exposed surface of signs except those required by local ordinance, which shall be applied in an inconspicuous location.
- G. A "UL" label must be placed on every separate electrical sign element (i.e. every sign cabinet or channel letter.
- H. Sign contractor shall repair any damage to any work caused by his work.
- I. Lessee shall be fully responsible for the operations of Lessee's sign contractor.
- J. Lessee shall remove all signs within 15 days of vacating the premises and shall repair any damage therefrom.

VI. CONTRACTOR REQUIREMENTS

- A. Inspection: Prior to acceptance and final payment for the Work by Lessee, Lessor's representative for conformance to the criteria set forth herein shall inspect each sign. Signs installed without such approval are subject to removal at the Lessee's expense.
- B. Guarantee: Lessee's sign fabrication and installation company shall carry Workmen's Compensation and Public Liability Insurance against all damage suffered or done to any and all persons and/or property while engaged in the construction and/or erection of the signs in the amount of One Million (\$1,000,000.00) Dollars.

VII. NO ASSURANCES

- A. Lessee acknowledges that the Lessor and its representatives give no assurances that the sign approved by the Lessor or its representative, which is in accordance

with the provisions of this criteria, will be acceptable to the applicable governmental regulating authorities.

- B. Lessee shall be solely responsible for bringing its sign into compliance with all applicable rules, ordinances and building codes.

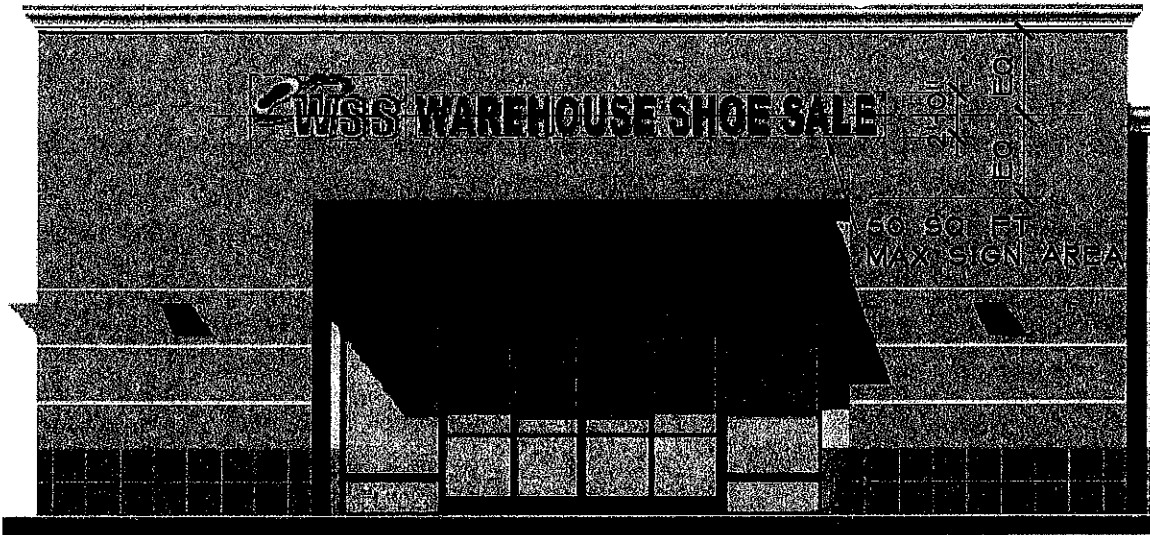

PARTIAL EAST ELEVATION

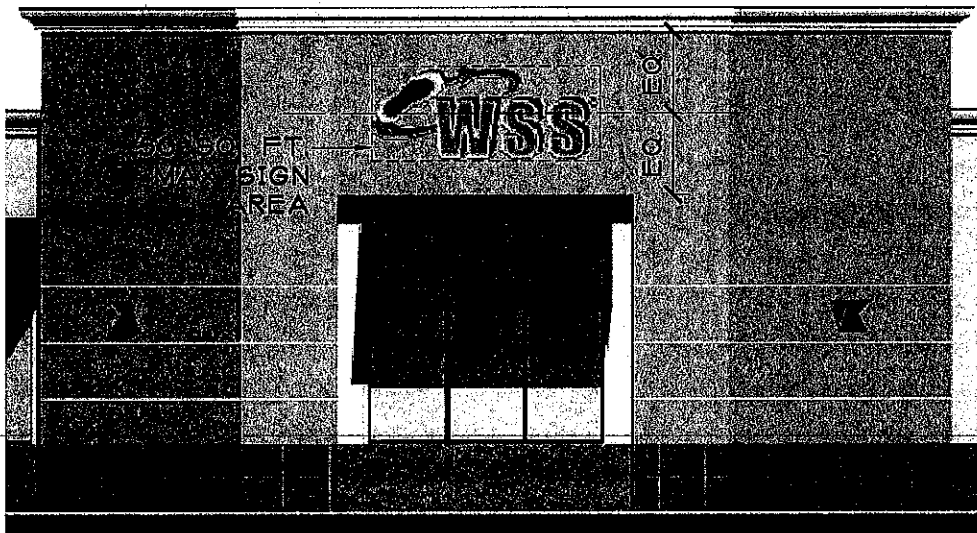

SOUTHWEST ELEVATION



PARTIAL SOUTH ELEVATION

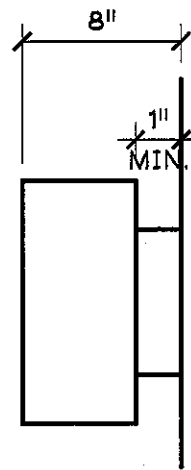

TYPICAL SIGNAGE SECTION

EXHIBIT "B" WALL SIGNS

2330 SAVIERS RD.
OXNARD, CA

T. W. LAYMAN ASSOCIATES
CAL ASIA DEVELOPMENT

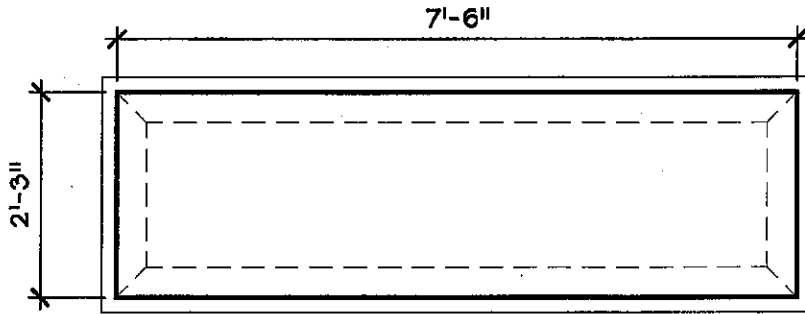

SHT. MET. SIGN
FRAMEWORK

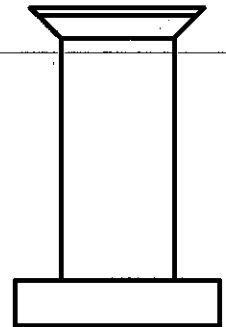
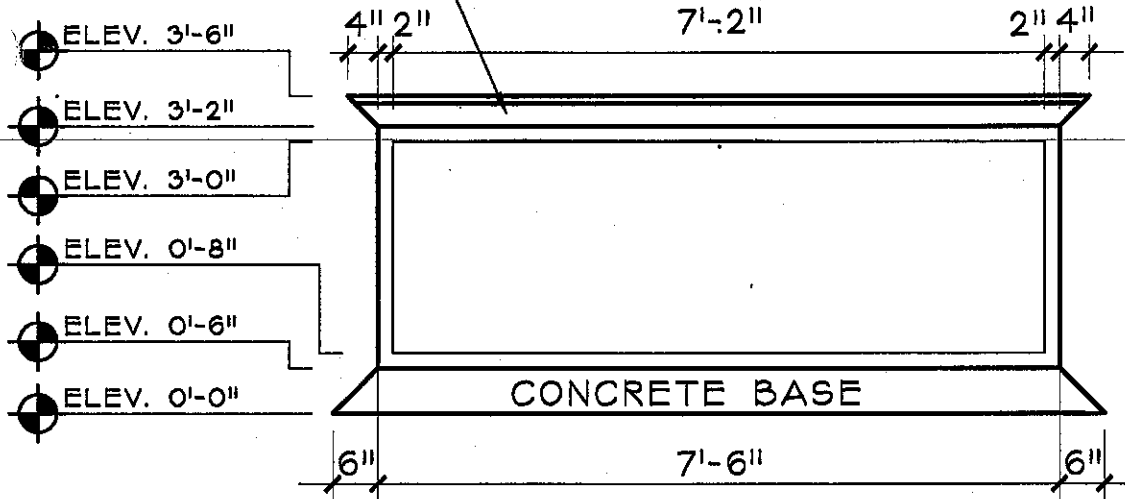

EXHIBIT "C" MONUMENT SIGN

2330 SAVIERS RD.
OXNARD, CA

T. W. LAYMAN ASSOCIATES
CAL ASIA DEVELOPMENT

