

Exhibits B, D, K, M, ... y

APPROVED  
 BY: 04-140-26<sup>th</sup> 03-500-17  
 DATE: 7/15/04  
 CITY OF OXNARD  
 PLANNING

# Centennial Plaza

'B' Street And 5th Street, Oxnard, California

## Written Criteria / Wall Sign Standards

Prepared For:  
 Strand Cinemas LLC  
 340 Rosewood Avenue, Suite D  
 Camarillo CA 93010

Prepared By:



1749 E. 28th Street  
 Signal Hill CA 90755

APPROVED  
 BY: PL Reso 03.94  
 DATE: 11/16/03  
 CITY OF OXNARD  
 PLANNING

owner + SMI  
 to sign off on  
 signs prior to  
 Planning signature



## PROJECT INFORMATION:

### DEVELOPER:

Company: Strand Cinemas LLC  
Address: 340 Rosewood Avenue, Suite D  
Camarillo CA 93010  
Phone: 805.987.6921  
Fax: 805.987.0152  
e-mail: n.spondello@verizon.net

### ARCHITECT:

Company: The Henry Architects  
Contact: Rob Henry  
Address: 6203 Dayton Avenue North  
Seattle WA 98103  
Phone: 206.784.6964  
Fax: 206.784.0837  
e-mail: henryarchitects@qwest.net

### SIGNAGE CONSULTANT:

Company: Sign Methods, Inc.  
Contact: Lynn Cathcart  
Address: 246 Bayside Way  
Newport Beach CA 92660  
Phone: 949.673.7033  
Fax: 949.673.0733  
Cell: 714.342.2211  
E-mail: signperson2000@aol.com

### LANDSCAPE ARCHITECT:

Company: Jordan-Gilbert Landscape Architects  
Contact: Paul Jordan  
Address: 3350 Loma Vista Road  
Ventura CA  
Phone: 805.642.3641

# Centennial Plaza

## SIGN PROGRAM

### Location:

'B' Street & 5th Street  
Oxnard, CA

### Date:

April 18, 2003

### Last Revised:

September 10, 2003



1749 E. 28th St.  
Signal Hill, CA 90755  
(562) 989-5755  
(800) 655-4336  
Fax: (562) 427-6875  
www.signmethods.com

## CONTACTS

# Centennial Plaza

## **SIGN PROGRAM**

### **Location:**

'B' Street & 5th Street  
Oxnard, CA

### **Date:**

April 18, 2003

### **Last Revised:**

September 10, 2003



1749 E. 28th St.  
Signal Hill, CA 90755  
(562) 989-5755  
(800) 655-4336  
Fax: (562) 427-6875  
[www.signmethods.com](http://www.signmethods.com)

## **Sign Criteria**

| Subject                                | Page |
|--|------|
| Purpose and Intent                     | 1    |
| General Landlord / Tenant Requirements | 1    |
| General Specifications                 | 1    |
| Prohibited Signs                       | 2    |

## **Graphic Exhibits**

|  |   |
|--|---|
| Site Plan                                      | A |
| Building Elevations                            | B |
| Wall Sign - Shop Tenant                        | C |
| Wall Sign - Cinema                             | D |
| Freestanding Sign - Plaza / Multi-Tenant I.D.  | E |
| Freestanding Sign - Cinema                     | F |
| Pedestrian Blade Sign                          | G |
| Window Sign                                    | H |
| Tenant Suite Entrance Identification And Hours | I |
| Clock Tower                                    | J |
| Cinema Wall Sign                               | K |
| Off-Site Ground Sign                           | L |

**I N D E X**



**SIGN PROGRAM**

**Location:**

'B' Street & 5th Street  
Oxnard, CA

**Date:**

April 18, 2003

**Last Revised:**

September 10, 2003



1749 E. 28th St.  
Signal Hill, CA 90755  
(562) 989-5755  
(800) 655-4336  
Fax: (562) 427-6875  
www.signmethods.com

**A. PURPOSE AND INTENT**

The purpose of this sign program is to ensure that the signage in Centennial Plaza reflects the integrity and overall aesthetic values of the Landlord and the City of Oxnard. Conformity with this program will be strictly enforced, and any non-conforming signs will be removed by the Landlord at the expense of the Tenant.

**B. GENERAL LANDLORD / TENANT REQUIREMENTS**

1. Prior to manufacture of any sign in the Plaza, the Tenant shall submit to Landlord or Landlord's agent for written approval, two copies of the detailed drawings. These drawings shall include the building elevation to which the signs are to be attached, sign dimensions, graphics, location, colors, fabrication specifications, and method of attachment. This approval must be obtained prior to submittal to the City of Oxnard.
2. All signs shall be reviewed for conformance with this criteria and overall design quality. Approval or disapproval of sign submittals based on aesthetics of design shall remain the sole right of the Landlord and/or Landlord's agent.
3. Prior to the manufacture and installation of any sign, the Tenant shall obtain a sign permit from the City of Oxnard.
4. Each Tenant must negotiate and pay all costs associated with that Tenant's wall sign(s), including related materials and installation fees, final inspection and permit costs. Tenant must pay a pro rata share of any signage permitted by Landlord on any monument sign, as specified in lease.
5. Tenant fascia signs will be limited to Tenant's name, logo, and/or logotype. The use of brand name logos will not be allowed on the sign unless it is specifically included in the Tenant D.B.A.
6. It is the responsibility of the Tenant's sign company to verify all conduit and transformer locations and service access prior to fabrication.
7. In the event a Tenant vacates his premise, it is his responsibility to patch all holes and paint surface(s) to match existing color of fascia. In addition, the Tenant shall provide a blank panel for any freestanding sign he occupies.
8. Landlord reserves the right to periodically hire an independent electrical engineer, at Tenant's sole expense, to inspect the installation of all Tenant's signs. Tenants will be required to have any discrepancies and/or code violations corrected at Tenant's expense. Any code violations, requests for sign removals, or discrepancies not corrected within fifteen (15) days of notice, may be corrected by the Landlord at Tenant's expense.

9. All Tenant signs shall be installed prior to opening for business, only after city permits are secured.
10. Cooperative Tenant advertising, signing or seasonal event signing will require a special event sign permit from the City of Oxnard.

**C. GENERAL SPECIFICATIONS**

1. Sign sizes shall be limited to maximum widths shown on Tenant's elevation, and also shall not exceed the general sizes outlined.
2. Signs shall be fabricated per the specifications shown.
3. All signs and their installation shall comply with all local building and electrical codes.
4. All electrical signs will be fabricated by a U.L. approved sign company, according to U.L. specifications.
5. Sign company to be fully licensed with the City and State and shall have full workman's compensation and \$2,000,000.00 liability insurance.
6. All penetrations of exterior fascia are to be sealed watertight. Color and finish to match existing building exterior.
7. All conduits, transformers, junction boxes and openings in building surfaces shall be concealed. Exposed hardware shall be finished in a manner consistent with quality fabrication practices. No exposed raceways will be allowed.
8. Signs shall be placed in locations as shown on elevations with landlord approval.
9. All signs shall display required U.L. labels per U.L. code. Label placement shall be consistent throughout sign.
10. Any Tenant sign left thirty (30) days after vacating premises shall become the property of the landlord unless previous arrangements have been agreed upon by landlord and Tenant.
11. Any visible spacers used in sign installation must be painted to match building fascia color.



**SIGN PROGRAM**

**Location:**

'B' Street & 5th Street  
Oxnard, CA

**Date:**

April 18, 2003

**Last Revised:**

September 10, 2003



1749 E. 28th St.  
Signal Hill, CA 90755  
(562) 989-5755  
(800) 655-4336  
Fax: (562) 427-6875  
www.signmethods.com

**D. PROHIBITED SIGNS**

1. **Signs Constituting a Traffic Hazard**  
No person shall install or maintain, or cause to be installed or maintained, any sign which simulates or imitates in size, color, lettering or design any traffic sign or signal, or which makes use of the words "STOP", "LOOK", "DANGER" or any other words, phrases, symbols or characters in such a manner as to interfere with, mislead, or confuse traffic.
2. **Signs in Proximity to Utility Lines**  
Signs which have less horizontal or vertical clearance from authorized communication or energized electrical power lines than are prescribed by the Laws of the State of California are prohibited.
3. Letters painted on any wall will not be permitted.
4. Cabinet type wall signs will not be allowed.
5. There shall be no rooftop signs.
6. Other than the Cinema marquee, a sign shall not flash, scintillate, move, change color, appear to change color or change intensity, or contain any part or attachment which does the same.
7. Banner, pennants, flags, and captive balloons are not permitted except that, subject to issuance of a temporary use permit pursuant to City Code Section 34-4.1 et seq., any or all of the above shall be authorized by the planning director for a period not to exceed one month for the purpose of a grand opening. Tenant must first secure Landlord and Landlord Agent approval for such sign before proceeding to obtain the required City permits.
8. Signs must be architecturally compatible with the entire center and receive approval of landlord and city zoning, planning and building departments.
9. No sign shall project above the approved sign envelope.
10. Portable, movable signs are prohibited, including those placed on or within a vehicle. Paper, cloth, or similar temporary signs are not permitted on the exterior of any building unless placed within glassed showcase or permanently framed are designated for that purpose and approved by Landlord or Landlord's agent.
11. Billboard Signs are not permitted.
12. The use of a permanent sale sign is prohibited.

# Centennial Plaza

## SIGN PROGRAM

**Location:**

'B' Street & 5th Street  
Oxnard, CA

**Date:**

April 18, 2003

**Last Revised:**

September 10, 2003



1749 E. 28th St.  
Signal Hill, CA 90755  
(562) 989-5755  
(800) 655-4336  
Fax: (562) 427-6875  
www.signmethods.com

Scale: 1" = 80'

## SITE PLAN

Exhibit A

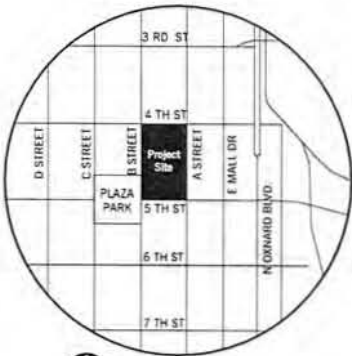

VICINITY PLAN

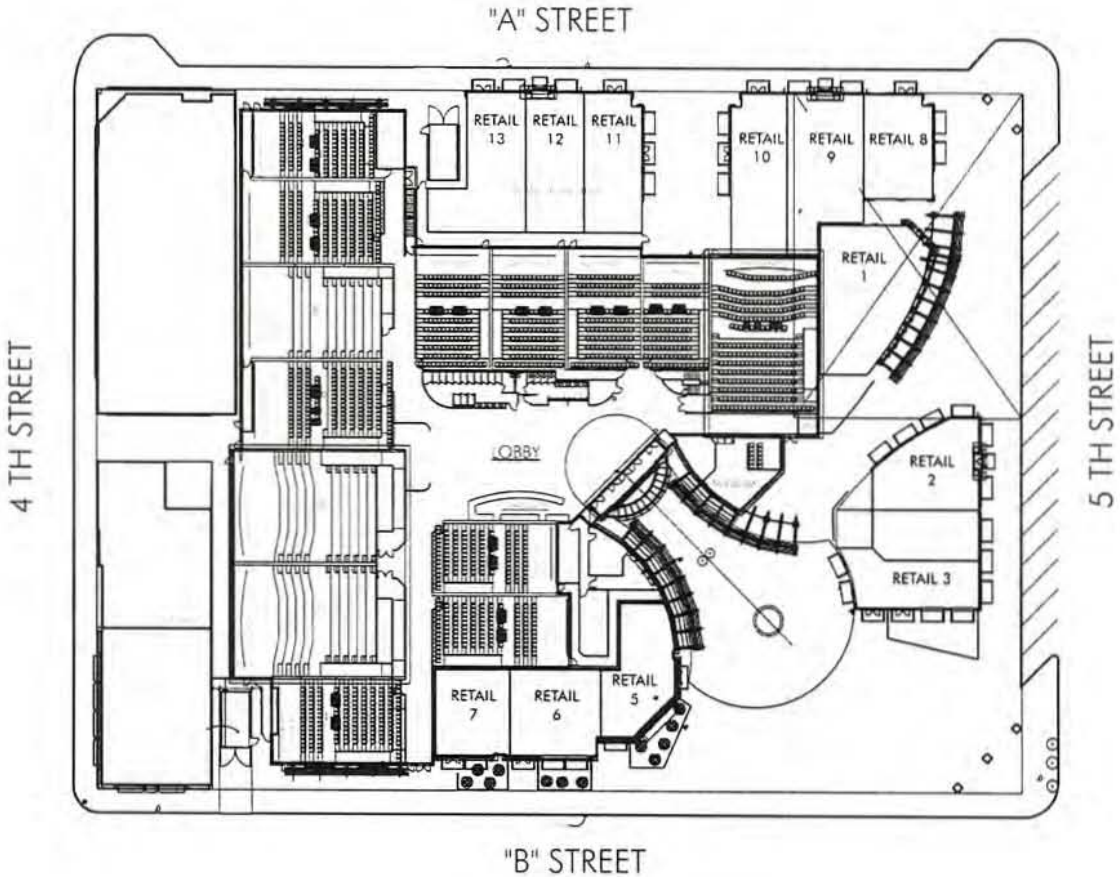

"B" STREET

SITE PLAN

# Centennial Plaza

## SIGN PROGRAM

**Location:**  
 'B' Street & 5th Street  
 Oxnard, CA

**Date:**  
 April 18, 2003

**Last Revised:**  
 September 10, 2003



Phase II Retail

5TH STREET ELEVATION



Phase II Retail

A STREET ELEVATION



B STREET ELEVATION

■ = SHOP Tenant WALL SIGN LOCATION



1749 E. 28th St.  
 Signal Hill, CA 90755  
 (562) 989-5755  
 (800) 655-4336  
 Fax: (562) 427-6875  
 www.signmethods.com

## BUILDING ELEVATIONS

Exhibit B

# Centennial Plaza

## SIGN PROGRAM

**Location:**

B' Street & 5th Street  
Oxnard, CA

**Date:**

April 18, 2003

**Last Revised:**

September 10, 2003



Phase II Retail

5TH STREET ELEVATION

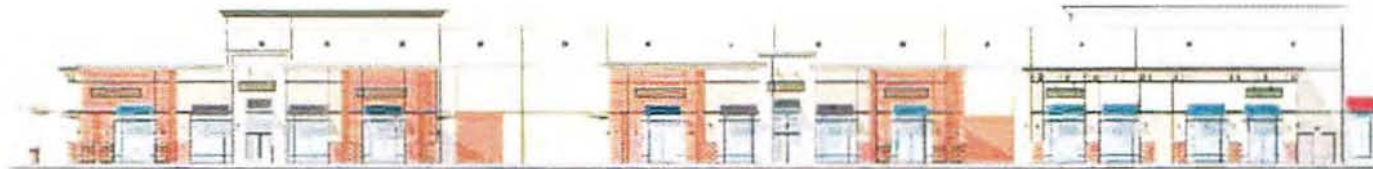

Phase II Retail

A STREET ELEVATION



B STREET ELEVATION



1749 E 28th St  
Signal Hill, CA 90755  
(562) 989-5755  
(800) 655-4336  
Fax: (562) 427-6875  
www.signmethods.com

**APPROVED**

BY: 04-140-26

DATE: \_\_\_\_\_

**CITY OF OXNARD  
PLANNING**

 - SHOP Tenant WALL SIGN LOCATION

## BUILDING ELEVATIONS

Exhibit B



## SHOP TENANT WALL SIGN

- Quantity:** Maximum of one (1) per Tenant leasehold elevation, total of three (3) signs maximum per Tenant.
- Size:** Height not to exceed 24", except that descending portions of script letters or exaggerated capital letters may exceed this by six (6) inches, with Landlord approval. Length of sign may not exceed seventy-five (75) percent of the width of the fascia it occupies.
- Sign Area:** Front elevation: Max. two (2) square feet per lineal foot of leasehold frontage. Side elevation: Max. one (1) square foot per lineal foot of leasehold frontage. Rear elevation: Max. one (1) square foot per lineal foot of leasehold frontage.
- Letter Construction And Illumination Options:**
- Individual flat-cut-out or dimensional externally illuminated letters, installed pin-mounted off building fascia a maximum of 1-1/2 inches. Minimum overall letter thickness is one-half (1/2) inch. External illumination to be gooseneck lamps, architecturally compatible with and painted in harmony with building features. Paint finish must be automotive enamel over primer undercoat. Detail on face of sign (eg. handtooled lettering appearance, outline, etc.) may be achieved by dimensional overlay only; the use of applied pressure-sensitive vinyl is prohibited.
  - Reverse-pan halo illuminated channel letters, minimum 0.063 aluminum construction with minimum 0.090 aluminum faces and 3/16" thick clear Lexan back lenses. Faces and returns of letters to be painted or have natural metallic finish, in color of Tenant's choice with Landlord and City approval. Letters to be installed pin-mounted 1-1/2 inches off building fascia, to allow neon or LED halo illumination, in White, Red, Yellow, Green, or Blue. Detail on face of letters (eg. handtooled letter appearance, outline, etc.) may be achieved by painting the letter face or by dimensional substrate overlay; the use of applied pressure-sensitive vinyl is prohibited. Illuminated detail on face of channel may be achieved by using routed push-thru acrylic (white or clear with solid translucent vinyl overlay). Paint finish must be automotive enamel over primer undercoat.
  - Standard pan internally illuminated channel letters, minimum 0.040 aluminum construction with 3/16 inch thick acrylic faces and 3/4 inch trimcap retainer. Return depth to be 5 inches. Internal neon or L.E.D. illumination in Red, Yellow, Green, or Blue, chosen for optimal illumination of acrylic face. Returns of letters to be painted or have natural metallic finish. If returns are painted, automotive enamel over primer undercoat must be used. Colors of face, trimcap, and returns to be Tenant's choice with Landlord and City approval. Letters to be installed pin-mounted 1/2 inch off building fascia.
- Logos:** Logos may be fabricated and illuminated using either acceptable letter fabrication option listed above. Mixing of acceptable methods is encouraged.
- Neon Accents:** Exposed neon may be used in addition to any approved sign described above. Neon may either be installed directly to wall or to face of logo. Area of exposed neon may not exceed twenty-five (25) percent of overall sign area.



SAMPLE SHOP Tenant ELEVATIONS WITH SIGNAGE

**Centennial  
Plaza**

### SIGN PROGRAM

#### Location:

'B' Street & 5th Street  
Oxnard, CA

#### Date:

April 18, 2003

#### Last Revised:

September 10, 2003



1749 E. 28th St.  
Signal Hill, CA 90755  
(562) 989-5755  
(800) 655-4336  
Fax: (562) 427-6875  
www.signmethods.com

### SHOP TENANT WALL SIGN

Exhibit C

**CINEMA WALL SIGN**

Quantity: Cinema I.D. Sign  
 One (1) Movie Marquee Wall Sign, on 'B' Street side of tower only.

Size: Cinema Name: 8'-0" x 18'-0" (Max. height 48'-0"), Marquee: 8'-0" x 17'-0" (radius)

Area: Cinema  
 Cinema Name and '14': Total: 39.44 Sq.Ft., Marquee: 126 Sq.Ft.

Construction: To be determined

At

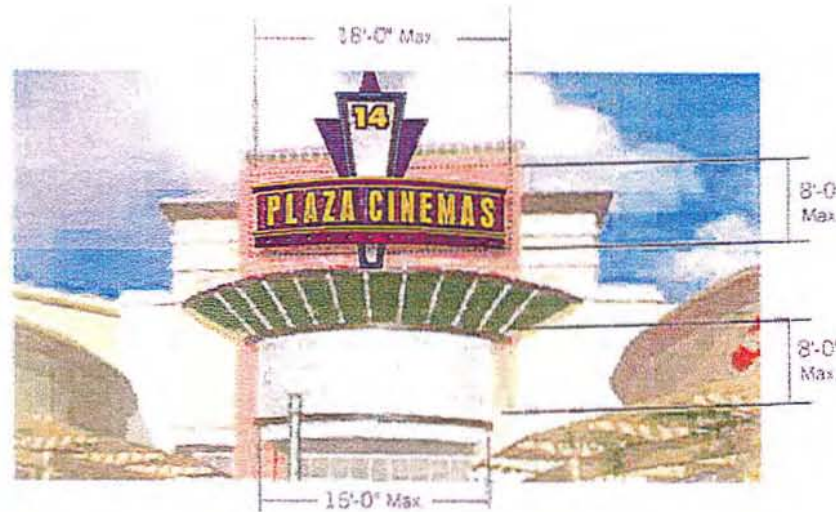

CINEMA TOWER ELEVATION FROM 'B' STREET

**APPROVED**

BY: 04-140-26

DATE: \_\_\_\_\_

**CITY OF OXNARD  
 PLANNING**

**Centennial  
 Plaza**

**SIGN PROGRAM**

**Location:**

B' Street & 5th Street  
 Oxnard, CA

**Date:**

April 18, 2003

**Last Revised:**

September 10, 2003

Se:



10989 BOATMAN AVENUE  
 STANTON, CA 90680  
 PHONE 714/761-8200  
 FAX 714/761-2451  
 WWW.SIGNSANOSERVICESCO.COM



1749 E 28th St  
 Signal Hill, CA 90755  
 (562) 989-5755  
 (800) 655-4336  
 Fax: (562) 427-6875  
 www.signmethods.com

**CINEMA  
 WALL SIGN**

Exhibit D

**GROUND SIGN: PLAZA/TENANT I.D.**

**Quantity:** One (1) double-faced sign.

**Size:** 26'-6" overall height.

**Construction And Illumination** Sign fabricated from aluminum with light textured painted finish. Plaza I.D. is 5" deep internally illuminated channel letters. Stripes are 1/2" thick clear push-thru acrylic with translucent vinyl overlay. Tenant panels are routed aluminum with 2" reverse pan returns. Copy and graphics are routed 1/2" thick clear push-thru acrylic with subsurface translucent vinyl decoration. Internal 800ma h.o. fluorescent illumination.

**Colors:** To be determined.

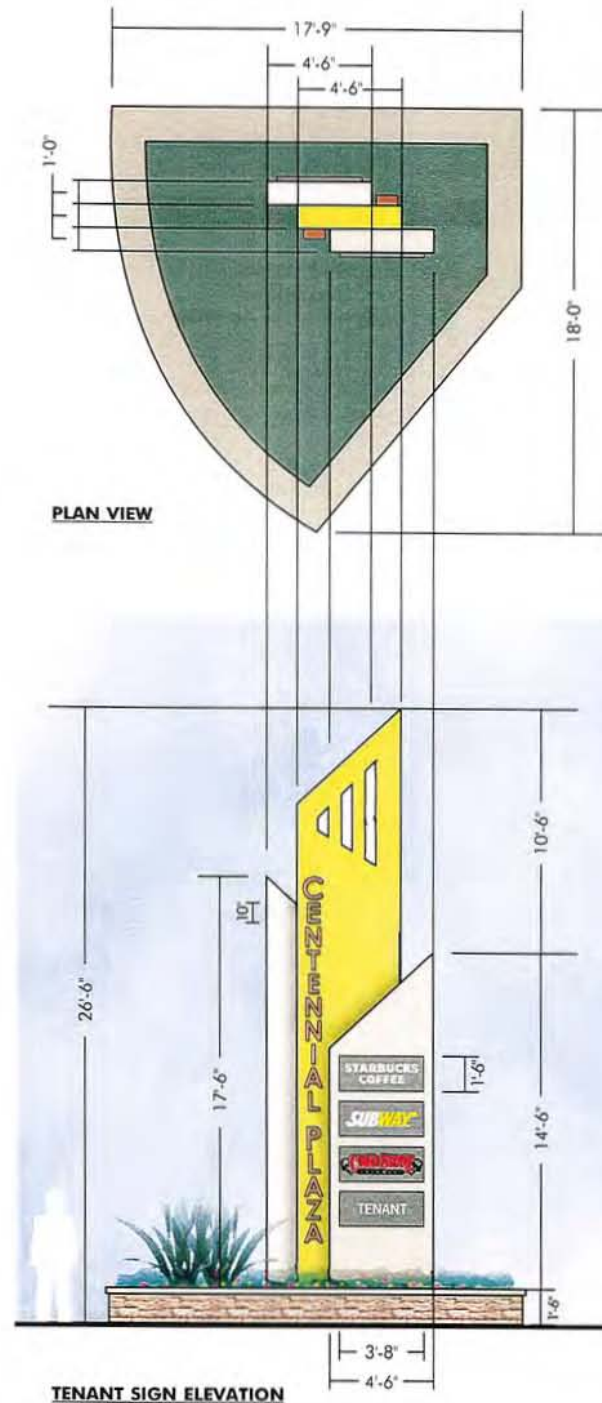

**Centennial Plaza**

**SIGN PROGRAM**

**Location:**

'B' Street & 5th Street  
Oxnard, CA

**Date:**

April 18, 2003

**Last Revised:**

September 10, 2003



1749 E. 28th St.  
Signal Hill, CA 90755  
(562) 989-5755  
(800) 655-4336  
Fax: (562) 427-6875  
www.signmethods.com

Scale: 1/8" = 1'-0"

**GROUND SIGN  
PLAZA/TENANT I.D.**

Exhibit E

**GROUND SIGN: CINEMA MARQUEE**

**Quantity:** One (1) double-faced sign.

**Size:** 35'-0" overall height.

**Construction And Illumination** Sign fabricated from aluminum with light textured painted finish. Plaza I.D. is 5" deep internally illuminated channel letters. Stripes are 1/2" thick clear push-thru acrylic with translucent vinyl overlay. Marquee cabinet is recessed into face and has lockable clear Lexan face and 2" wide aluminum retainer. White Lexan face with clear/black changeable copy. Internal 800ma h.o. fluorescent illumination.

**Colors:** To be determined.

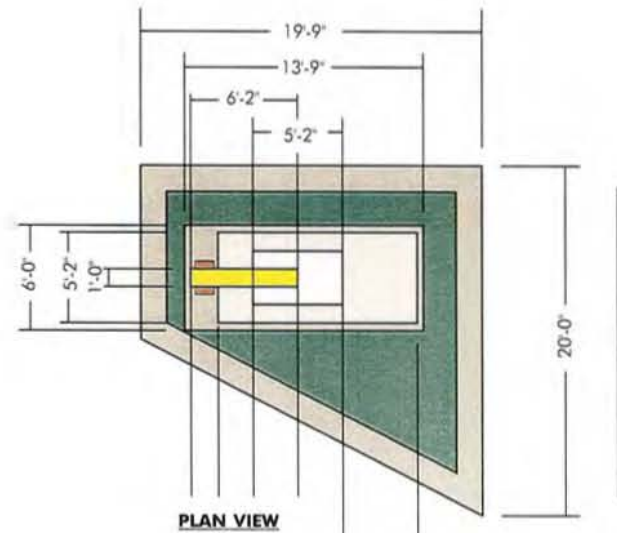

**PLAN VIEW**

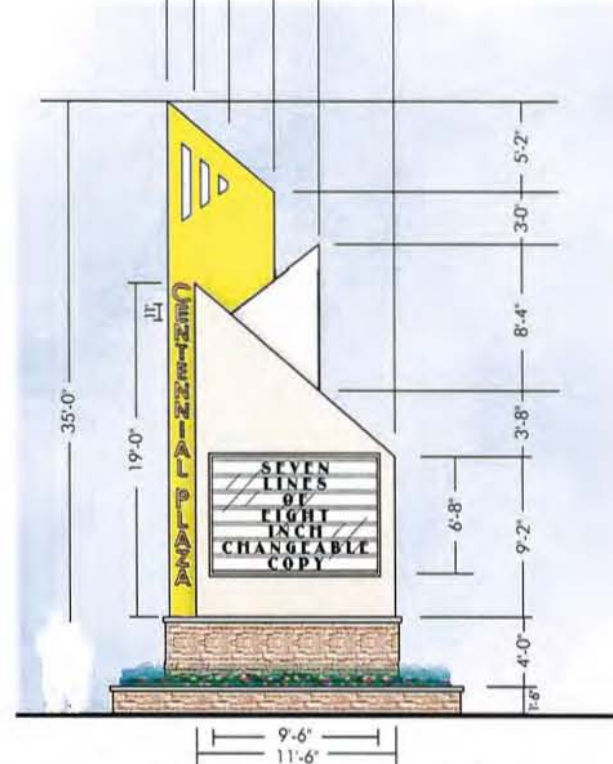

**CINEMA MARQUEE SIGN ELEVATION**

**Centennial Plaza**

**SIGN PROGRAM**

**Location:**

'B' Street & 5th Street  
Oxnard, CA

**Date:**

April 18, 2003

**Last Revised:**

September 10, 2003



1749 E. 28th St.  
Signal Hill, CA 90755  
(562) 989-5755  
(800) 655-4336  
Fax: (562) 427-6875  
www.signmethods.com

Scale: 3/32" = 1'-0"

**GROUND SIGN  
CINEMA MARQUEE**

Exhibit F

## SIGN PROGRAM

### Location:

'B' Street & 5th Street  
Oxnard, CA

### Date:

April 18, 2003

### Last Revised:

September 10, 2003



1749 E. 28th St.  
Signal Hill, CA 90755  
(562) 989-5755  
(800) 655-4336  
Fax: (562) 427-6875  
www.signmethods.com

## PEDESTRIAN BLADE SIGN

Exhibit G

## PEDESTRIAN BLADE SIGN

**Quantity:** One (1) sign max. per Tenant leasehold.

**Max. Sign Height:** Twenty-four (24) inches.

**Max. Sign Width:** Thirty six (36) inches.

**Construction:** Dimensional or layered P.V.C., sculpted or sandblasted high density foam, and / or redwood. The appearance of a minimum of three distinct layers is required. The use of icons representing the type of business conducted on-site is encouraged. All surfaces shall be painted, stained, or to feature natural metal finish.

**Colors:** Tenant's choice, with Landlord approval.

**Illumination:** Non-illuminated.

**Installation:** Suspended by black chain from ornamental bracket installed perpendicular to wall. Bracket is from Metal Craft Industries [www.metalcraftindustries.net/ScrollBracket.htm](http://www.metalcraftindustries.net/ScrollBracket.htm), part F43RSB.

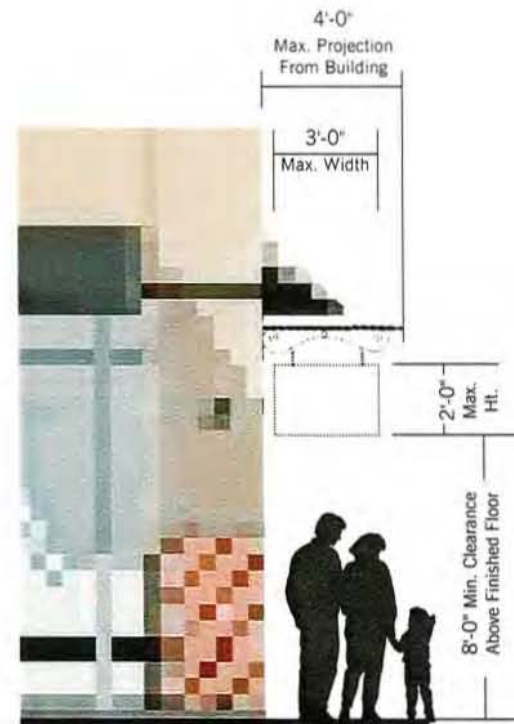
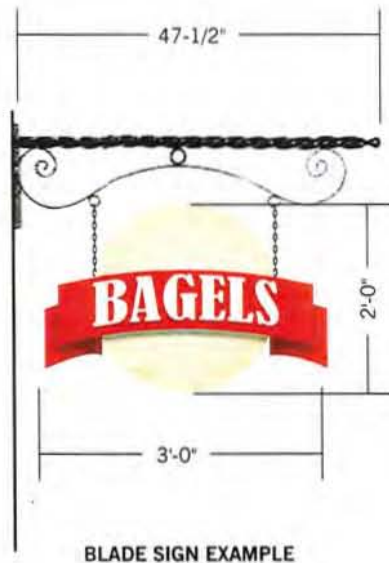

TYPICAL BLADE SIGN INSTALLATION

# Centennial Plaza

## SIGN PROGRAM

### Location:

'B' Street & 5th Street  
Oxnard, CA

### Date:

April 18, 2003

### Last Revised:

September 10, 2003



1749 E. 28th St.  
Signal Hill, CA 90755  
(562) 989-5755  
(800) 655-4336  
Fax: (562) 427-6875  
[www.signmethods.com](http://www.signmethods.com)

## WINDOW SIGN

Exhibit H

## WINDOW SIGN

(Other than Tenant Suite I.D / Hours)

**Quantity:** Maximum of one (1) window sign per Tenant.

**Size:** Any one window sign may not cover more than 20 percent of window it occupies.

**Types allowed:**

- Hanging neon sign, providing that sign does not blink.
- High-performance pressure-sensitive vinyl copy and graphics installed to interior side of window glass.

**Colors:** Neon: Any.  
Vinyl: White or frosted.



TYPICAL SHOP Tenant ELEVATION

Window sign may not cover  
more than 20 percent of  
window it occupies.

## SIGN PROGRAM

### Location:

'B' Street & 5th Street  
Oxnard, CA

### Date:

April 18, 2003

### Last Revised:

September 10, 2003



1749 E. 28th St.  
Signal Hill, CA 90755  
(562) 989-5755  
(800) 655-4336  
Fax: (562) 427-6875  
www.signmethods.com

## TENANT SUITE ENTRANCE I.D.

Exhibit I

## Tenant SUITE ENTRANCE IDENTIFICATION AND HOURS

**Quantity:** Maximum of one (1) per front and one (1) per rear elevation.

**Size:** As indicated below.

**Types allowed:** Front Entrance: High-performance pressure sensitive vinyl applied to inside of storefront window glass.  
Rear entrance: Wall plaque.

**Colors:** Front Entrance: White vinyl only.  
Rear Entrance: White vinyl copy on plaque painted to match SW 6272 "Plum Brown"

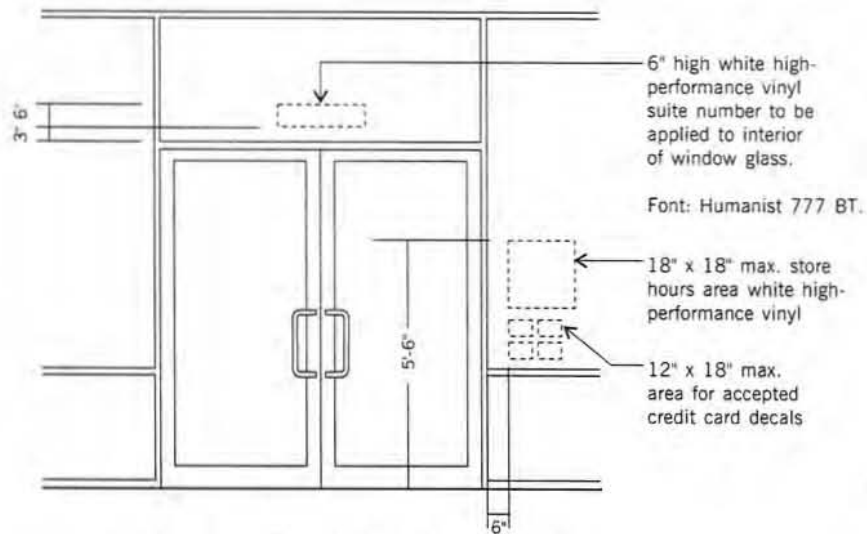

TYPICAL FRONT ENTRANCE ELEVATION

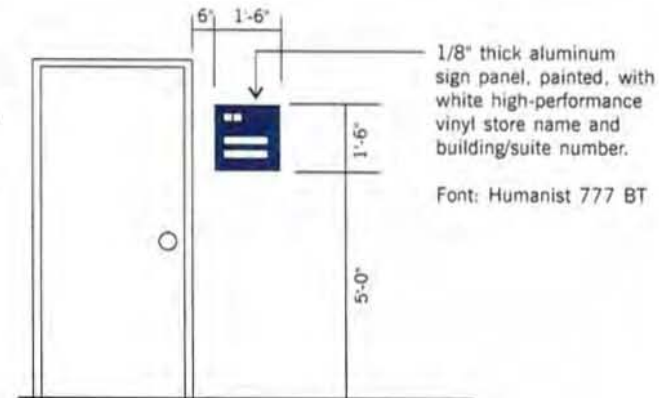

TYPICAL REAR ENTRANCE ELEVATION

# Centennial Plaza

## SIGN PROGRAM

### Location:

'B' Street & 5th Street  
Oxnard, CA

### Date:

April 18, 2003

### Last Revised:

September 10, 2003



1749 E. 28th St.  
Signal Hill, CA 90755  
(562) 989-5755  
(800) 655-4336  
Fax: (562) 427-6875  
www.signmethods.com

Scale: 1/8" = 1'-0"

## CLOCK TOWER

Exhibit J

## GROUND SIGN: CLOCK TOWER

Quantity: One (1) sign.

Size: 36'-6" overall height.

**Construction And Illumination** Sign fabricated from aluminum with light textured painted finish. Poster display cabinets are recessed into columns, with lockable clear Lexan faces.

Clock face and poster displays to internally illuminate.

Tower to externally illuminate via recessed lighting.

Colors: To be determined.



PERSPECTIVE VIEW

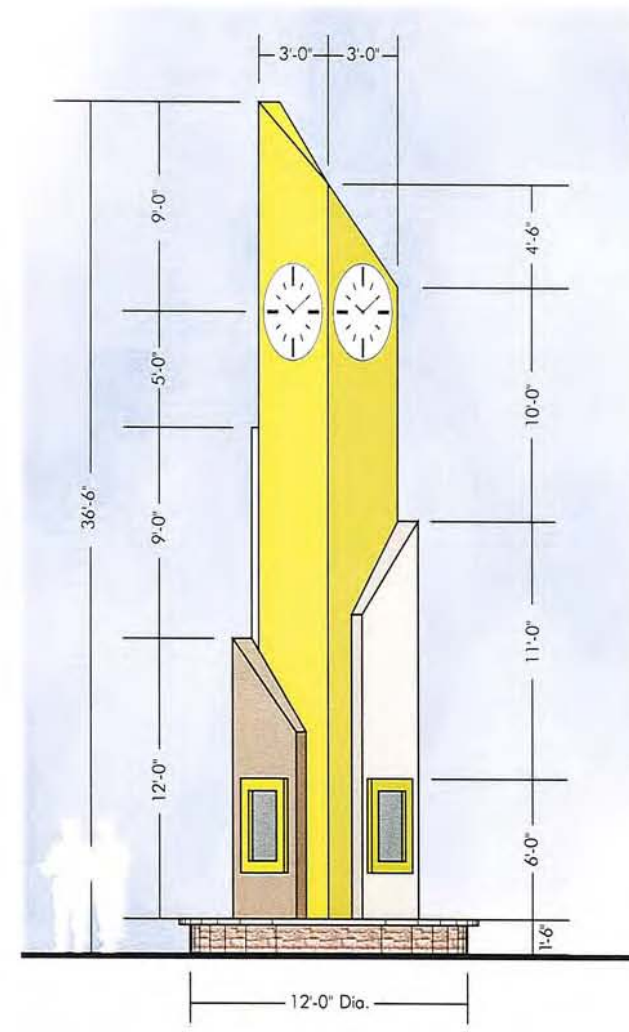

CLOCK TOWER ELEVATION



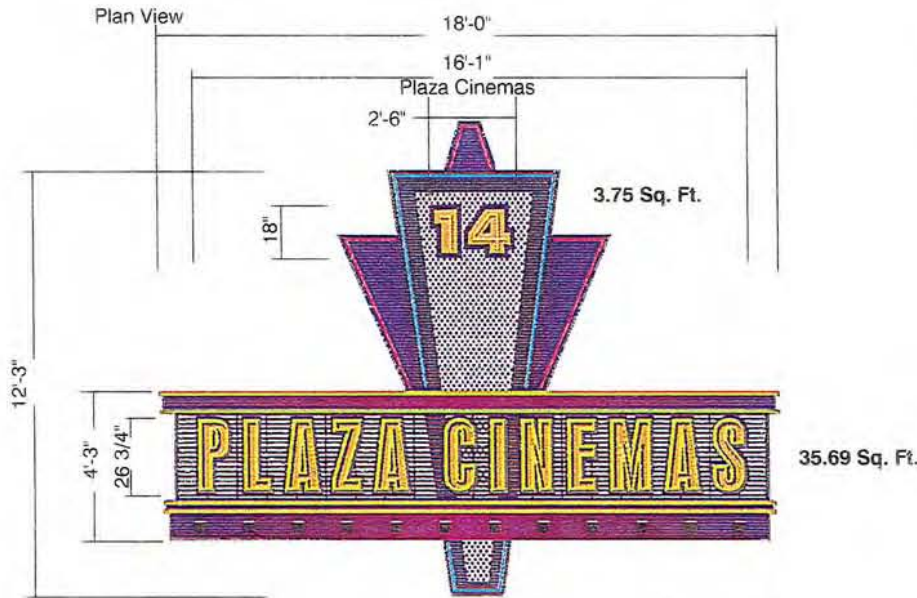
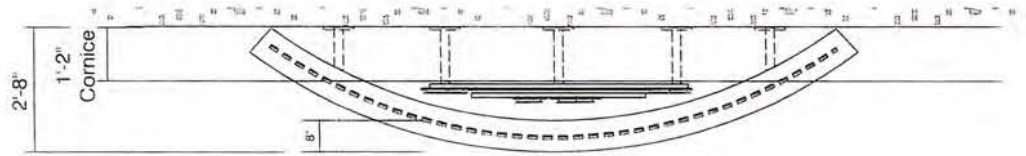

Scale: 3/16" = 1'-0"

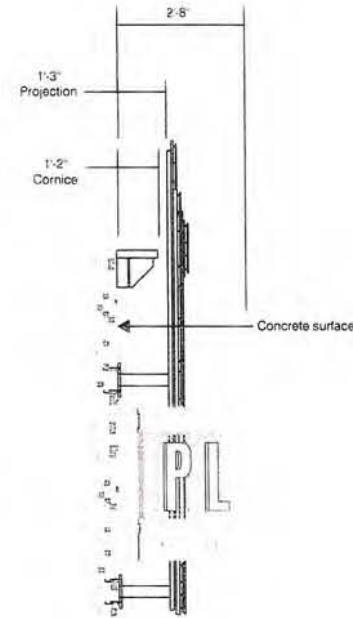

Side View

**WALL SIGN: CINEMA**

- Quantity:** (1) One sign, located on tower elevation facing 'B' Street
- Size:** 13'-5" overall height X 18'-0" overall length
- Area:** Area of copy = 39.44 Sq.Ft. overall
- Construction and Illumination:**
- 2" deep fabricated aluminum panel with exposed neon border
  - FCO '14' aluminum number with exposed single tube
  - Fabricated (radius) aluminum cabinet with aluminum grid background
  - Flat perforated aluminum panel pegged from surface 1/2"
  - 3" deep open faced channel letters with exposed neon. Letters mounted to FCO aluminum bkgd. letter
- Colors:** Violet, Reflex Blue and Golden Yellow

**APPROVED**  
 BY: 04 140 26  
 DATE: \_\_\_\_\_  
**CITY OF OXNARD**  
**PLANNING**

# Centennial Plaza

**SIGN PROGRAM**

Locations:

'B' Street & 5th Street  
Oxnard, CA

Date:

April 18, 2003

Last Revised:

September 10, 2003



10280 BOATMAN AVENUE  
STANTON, CA 90680  
PHONE 714-761-8700  
FAX 714-761-2451

WWW.SIGNSANDSERVICESCO.COM



**SIGN METHODS INC.**  
Electrical Signs And Neon

1749 E 28th St  
Signal Hill, CA 90755  
(562) 989-5755  
(800) 655-4336  
Fax: (562) 427-6875  
www.signmethods.com

Scale: 3/8" = 1'-0"

**CINEMA**  
**WALL SIGN**

Exhibit K

**GROUND SIGN: DIGITAL DISPLAY**

**Quantity:** One (1) double-faced sign.

**Size:** 35'-0" overall height.

**Construction And Illumination** Sign fabricated from aluminum with light textured painted finish. Stripes are 1/2" thick clear push-thru acrylic with translucent vinyl overlay. Digital display is recessed into face.

**Colors:** To be determined.

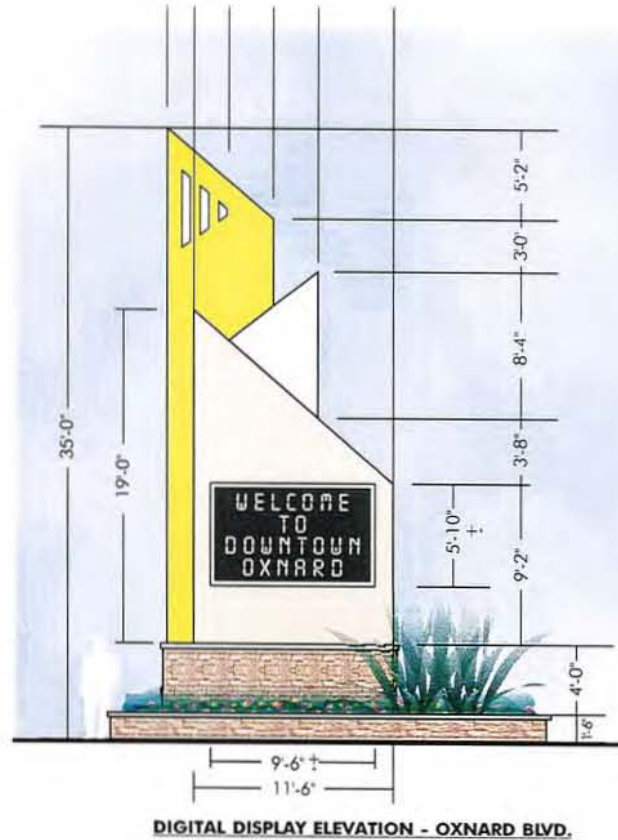
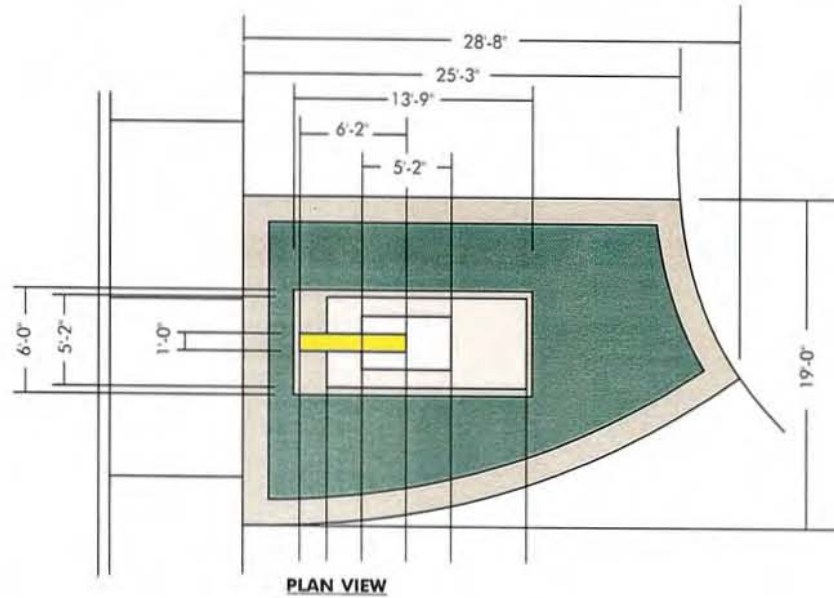

**Centennial Plaza**

**SIGN PROGRAM**

**Location:**

'B' Street & 5th Street  
Oxnard, CA

**Date:**

April 18, 2003

**Last Revised:**

September 10, 2003



1749 E. 28th St.  
Signal Hill, CA 90755  
(562) 989-5755  
(800) 655-4336  
Fax: (562) 427-6875  
www.signmethods.com

Scale: 3/32" = 1'-0"

**GROUND SIGN  
DIGITAL DISPLAY**

Exhibit L



### SIGN PROGRAM

**Location:**  
B' Street & 5th Street  
Oxnard, CA

**Date:**  
April 18, 2003  
**Last Revised:**  
September 10, 2003



10005 BOLTMAN AVENUE  
STANFORD, CALIFORNIA 94304  
PHONE 714/761-8200  
FAX 714/761-2451  
WWW.SIGNSANDSERVICES.COM



1749 E. 28TH ST  
Signal Hill, CA 90755  
(562) 969-5755  
(800) 655-4326  
Fax (562) 427-6875  
www.signmethods.com

Scale: 3/8" = 1'-0"

### CINEMA MARQUEE

Exhibit 2/M

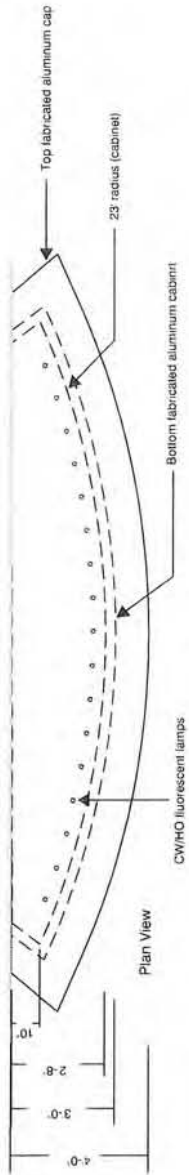

126 Sq. Ft. Scale: 3/16" = 1'-0"

#### WALL SIGN: CINEMA MARQUEE

(1) One sign, located on lower elevation facing B' Street

**Size:** 8'-0" overall height X 22'-0" overall length

**Area:** Sign face area 7'-0" x 18'-0" = 126 Sq. Ft.

#### Construction and Illumination:

Fabricated aluminum cabinet with 1 1/2" retainers painted Black gloss finish

White lexan face (radius face)

8" Black Change-Ad flat changeable letters & numerals with clear track attached to radius lexan face

Fabricated radius aluminum cabinets 'Top and Bottom' trim fastened to 'Marquee' cabinet

**Colors:** Black gloss finish

**APPROVED**  
BY: 04-146-26  
DATE: \_\_\_\_\_  
CITY OF OXNARD  
PLANNING