

# MERIDIAN OFFICE PARK

1900-1930 OUTLET CENTER DRIVE  
OXNARD, CA 93030

master sign program

## PREPARED FOR:

Martin Teitelbaum Construction  
569 Constitution Ave., Suite H  
Camarillo, CA 93012

## PREPARED BY:

Signs Pacific  
311 Hearst Drive  
Oxnard, CA 93030

|                            |   |
|----------------------------|---|
| APPROVED                   |   |
| BY:                        |  |
| DATE:                      | 5/15/08   |
| CITY OF OXNARD<br>PLANNING |   |

# objective

The purpose of this sign criteria is to establish standards that assure tenant signage is harmonious and integrates with the architecture of the center to provide coordinated proportional exposure for all tenants. This sign criteria also describes the responsibilities of the tenants with respect to sign review approval and installation. All work shall meet or exceed the minimum requirements shown in this document. A diversity of sign types within the parameters of these criteria is encouraged to allow for creative tenant signage. Any non-conforming signs that have been installed will be removed at tenant's expense.

# application procedure

The tenant shall submit two copies of the proposed sign to the landlord for review. Upon receiving landlord's signed approval, the tenant shall submit 3 copies to the city of Oxnard along with a copy of landlords signature. Renderings shall include scaled elevations of proposed sign(s) at tenant location with dimensions of tenant frontage and length of architectural surface on which the sign is to be installed. Additionally, a detailed, fully dimensional shop rendering depicting colors and materials, along with a section of the sign showing illumination source and method of attachment, as required by the City of Oxnard, shall be included with the submittal.

All costs associated with the acquisition, fabrication and installation of signage are the sole responsibility of the tenant. All sign contractor's working at the Meridian Park, must be fully, licensed, bonded, and have liability insurance.

Preferred Sign Vendor: Signs Pacific 311 Hearst Dr. Oxnard, CA 93030 (805)983-7446

# site plan

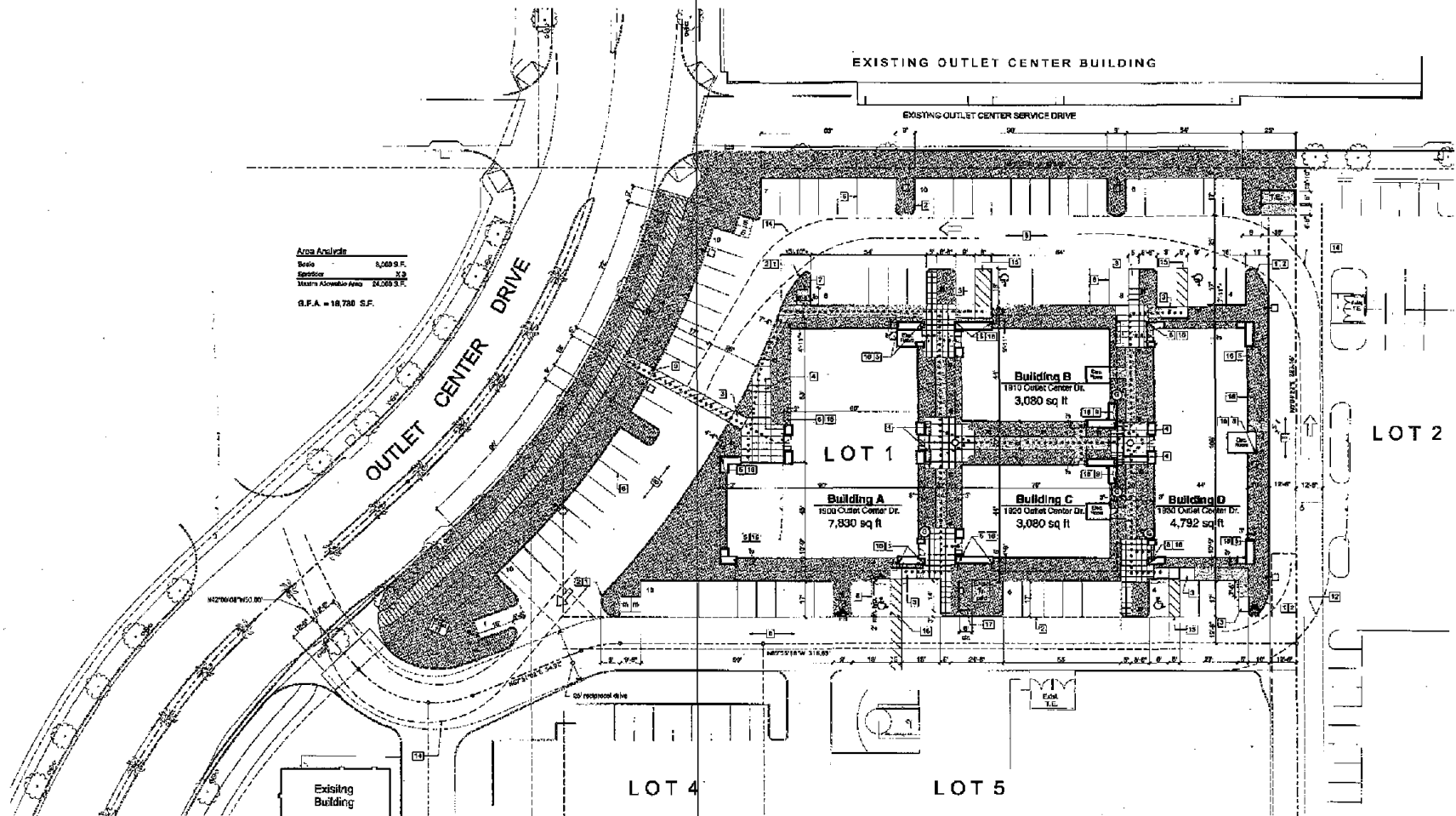

**Area Analysis**  
Basis: 5,000 S.F.  
Density: 3.2  
Maximum Allowable Area: 16,000 S.F.  
G.F.A. = 18,788 S.F.

Existing Building

LOT 4

LOT 5

LOT 1

LOT 2

EXISTING OUTLET CENTER BUILDING

EXISTING OUTLET CENTER SERVICE DRIVE

OUTLET CENTER DRIVE

# size requirements

Tenants are allowed up to 1.5 sq ft of sign area per linear foot of primary footage and ½ sq ft of sign area per linear foot of secondary frontage, subject to landlord and Meridian Office Park POA review. Sign areas are not transferable and can only be used on elevations from which the measurements are derived. The primary frontage is the elevation containing the public access. The secondary elevations are those which do not contain the public access. Sign length is restricted to 70% of the architecture surface on which it is installed or as specified on elevations. Maximum allowable signage includes all building signage.

Sign area is determined by the aggregate total of boxes that contain all letter forms and logo (graphic elements) comprising the sign. (see example below)

Maximum letter and logo heights combined shall not exceed 20% of the *height* of the architectural surface on which it is installed. Maximum individual letter and logo height shall not exceed 24". Letters shall have returns not exceeding 5" in depth. The bottom on the sign must be no less than 16' above grade.

These represent the maximums, the landlord and Meridian Office Park POA reserves the right to deny any submissions where these parameters are overstated in the context of the architecture (i.e. too crowded).

Signs/letters are required to fit the soffit/fascia of the building upon which they are installed and are not to interfere with the windows or any dimensional structures of the buildings.

All signs shall comply with the requirements of Article IX, Advertising Signs, of the Oxnard Municipal Code Book, as well as with the requirements of this sign program.



KANE & KERPER  
DENTISTRY

# fabrication requirements

Individual Channel letters are the primary sign format for Meridian Park. Letters are to be constructed from sheet metal or aluminum with 4" to 5" deep returns for standard and halo lit channel letters. 3" to 4" deep returns for reverse channel letters. Illumination to be provided by internal Light Emitting Diodes (LED's). All electrical fabrication requires U.L. approval. No exposed raceways are permitted.

Alternative to illuminated letters will be flat cut 1/4" aluminum clear natural satin finish letters and logos. Must be pin mounted with 1/2" stand offs.

Channel letter detail with internal LED illumination

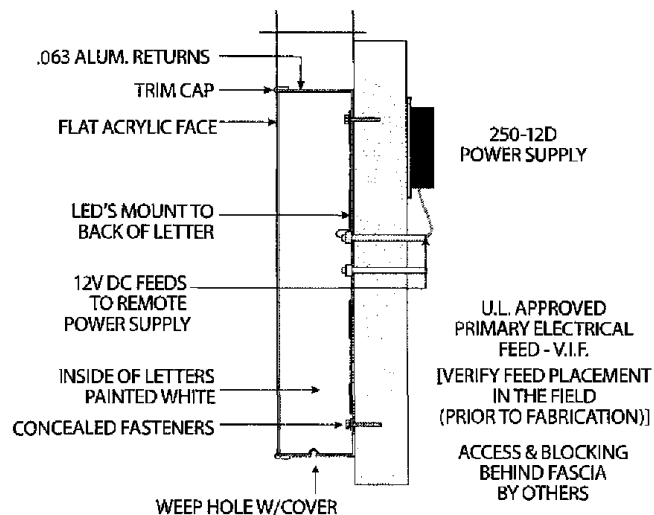

NOTE: IT IS THE CUSTOMERS RESPONSIBILITY TO PROVIDE 120 COLT PRIMARY ELECTRICAL SERVICE (INCLUDING GROUND WIRING *DIRECTLY* FROM PANEL BOX) WITHIN SIX FEET OF SIGNAGE. INSTALLATION TO MEET N.E.C. CODE

Non Illuminated Aluminum Letters

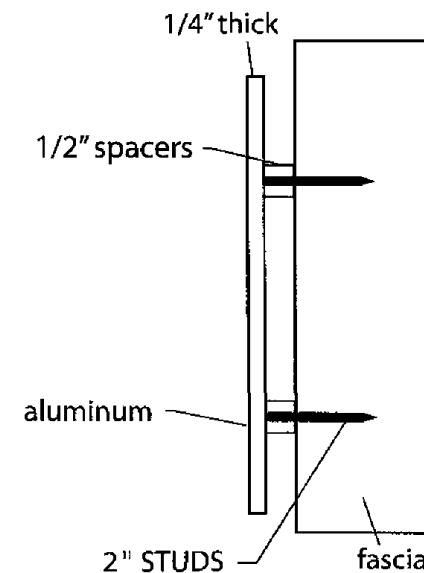

# non-permitted signs

1. Illuminated sign cabinets are not allowed, unless an integral part of the sign design, and/or are a part of the tenant subordinate copy, and specifically accepted by the Landlord.
2. No sign shall flash, scintillate, move, change color, appear to change color or change intensity or contain any part or attachment which does the same.
3. Banners, posters or window signs, temporary in nature, shall not be considered permanent signage, and shall be removed by the tenant when requested by the Landlord.
4. Signs shall not be installed or suspended from the ceiling or anywhere not approved by the Landlord.
5. No more than one sign per elevation. (This does not include window lettering, per 16-608 (6) window lettering limited to 20% of window)
6. Use of neon lighting prohibited.
7. All prohibitions called out under Division 4, Section 16-610 of City Code.

# building A

Address: 1900 Outlet Center Drive

Sign must be a minimum of 12" away from the edges of the building and a minimum of 12" from the top of the building and/or architectural feature.

Allowable sign areas are those that have Not To Exceed (NTE) measurements on them.

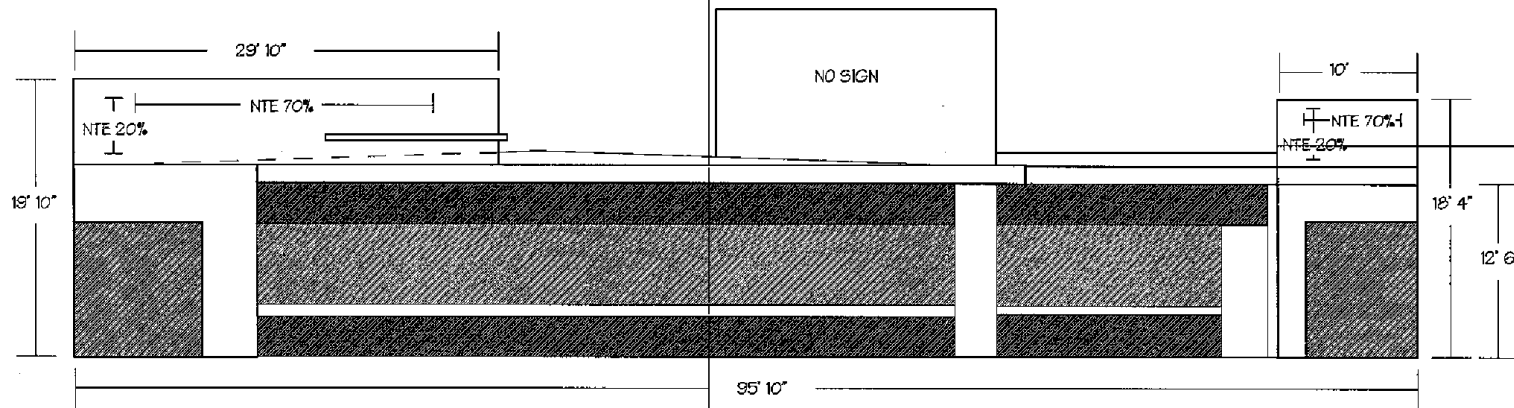

BUILDING A- NORTH ELEVATION

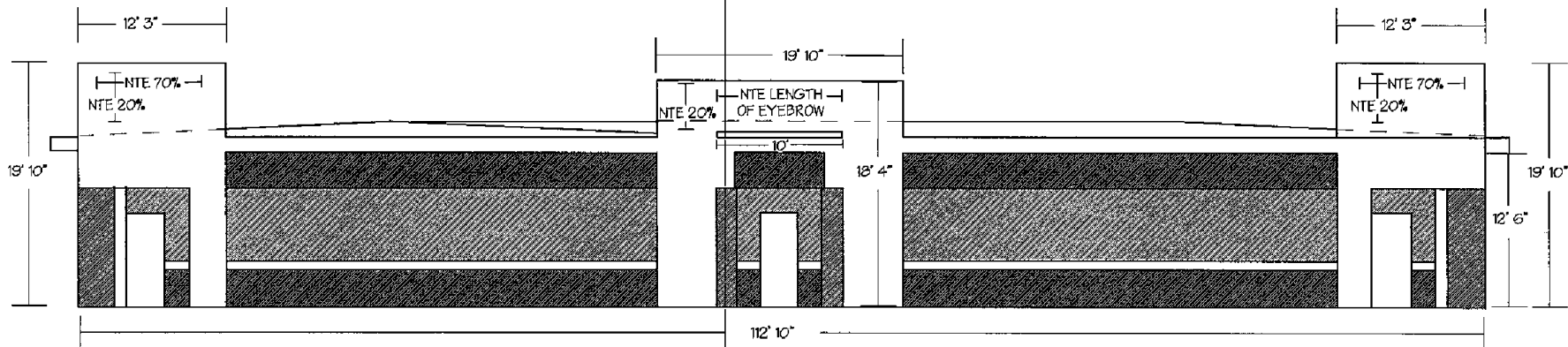

BUILDING A- EAST ELEVATION

# building A

Address: 1900 Outlet Center Drive

Sign must be a minimum of 12" away from the edges of the building and a minimum of 12" from the top of the building and/or architectural feature.

Allowable sign areas are those that have Not To Exceed (NTE) measurements on them.

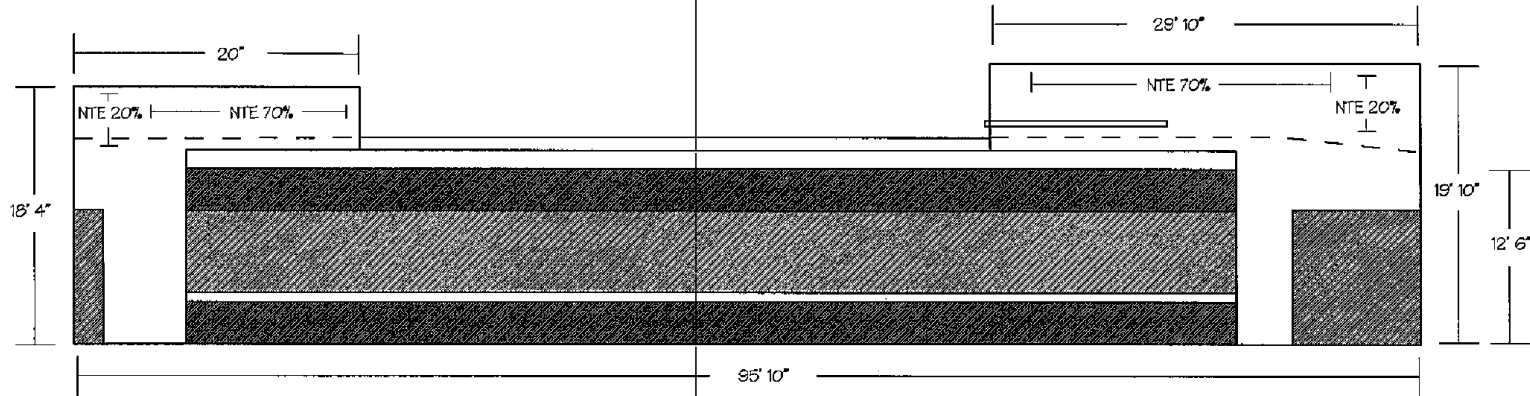

BUILDING A- SOUTH ELEVATION

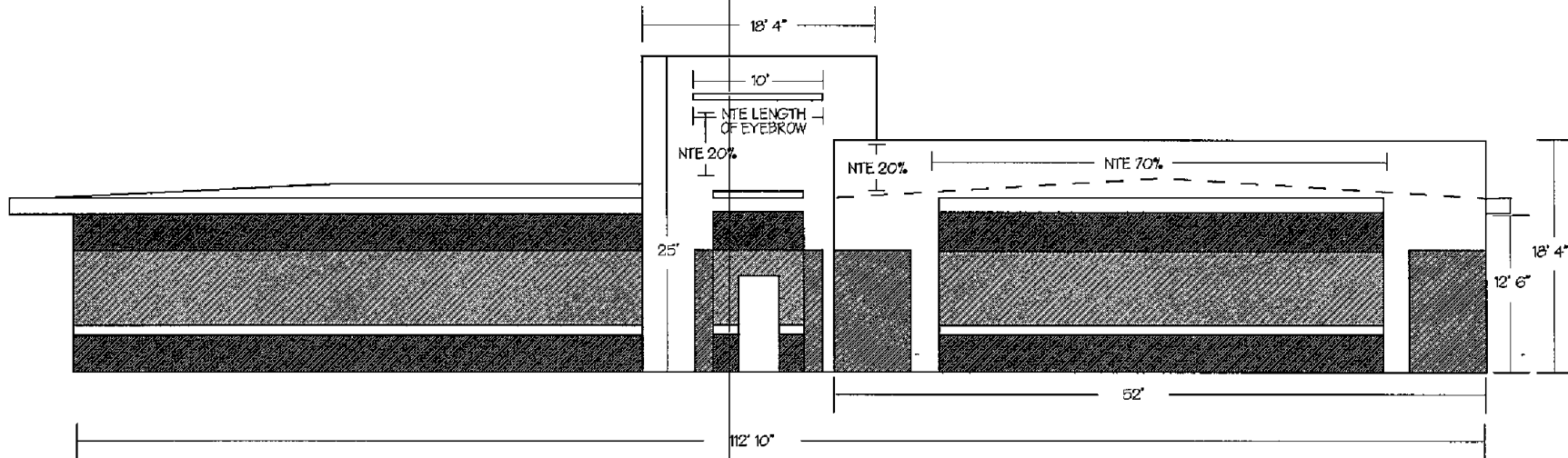

BUILDING A- WEST ELEVATION



# building B

Address: 1910 Outlet Center Drive

Sign must be a minimum of 12" away from the edges of the building and a minimum of 12" from the top of the building and/or architectural feature.

Allowable sign areas are those that have Not To Exceed (NTE) measurements on them.

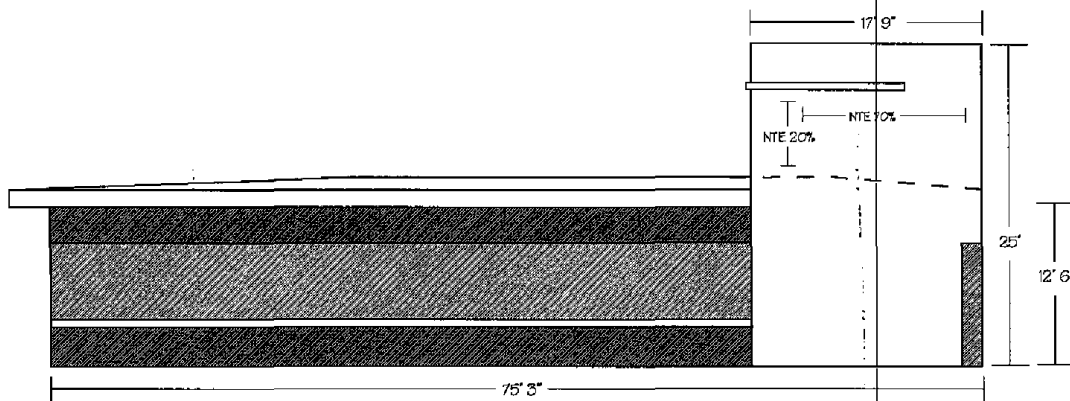

BUILDING B- NORTH ELEVATION

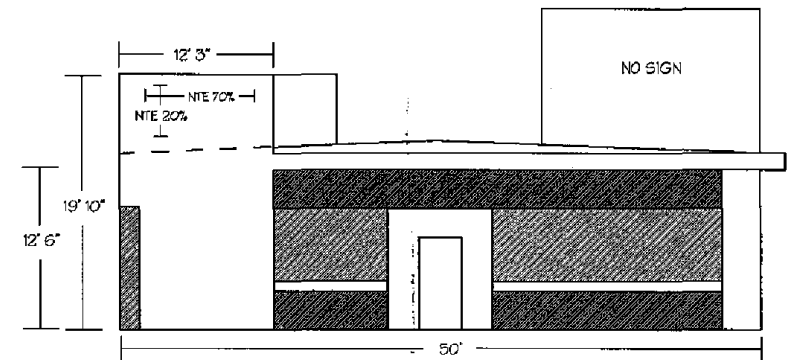

BUILDING B- EAST ELEVATION

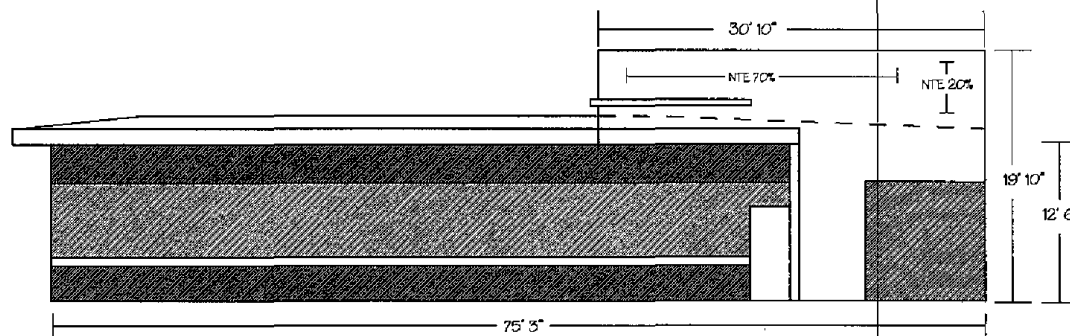

BUILDING B- SOUTH ELEVATION

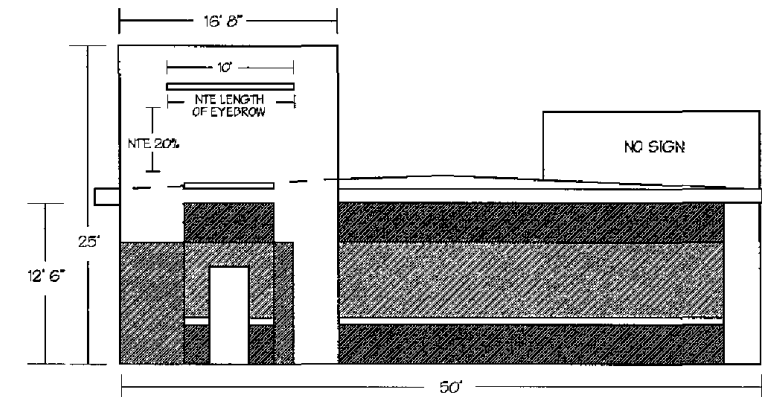

BUILDING B- WEST ELEVATION

# building C

Address: 1920 Outlet Center Drive

Sign must be a minimum of 12" away from the edges of the building and a minimum of 12" from the top of the building and/or architectural feature.

Allowable sign areas are those that have Not To Exceed (NTE) measurements on them.

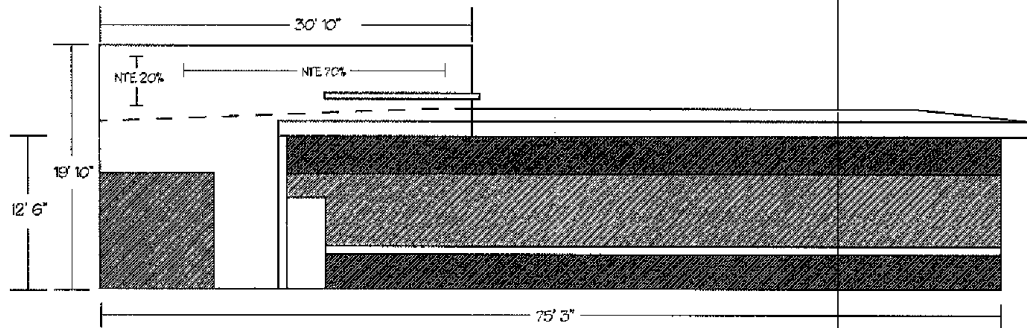

BUILDING C- NORTH ELEVATION

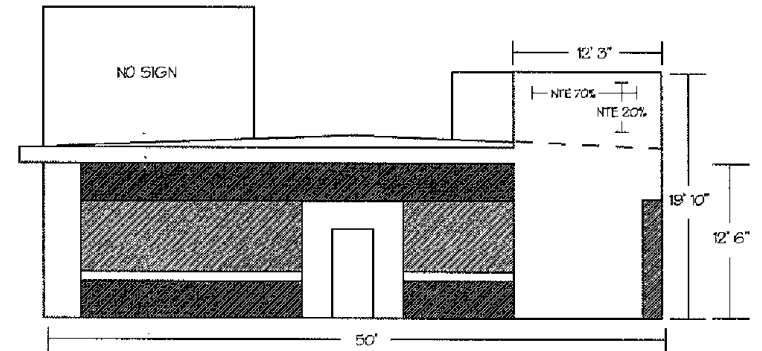

BUILDING C- EAST ELEVATION

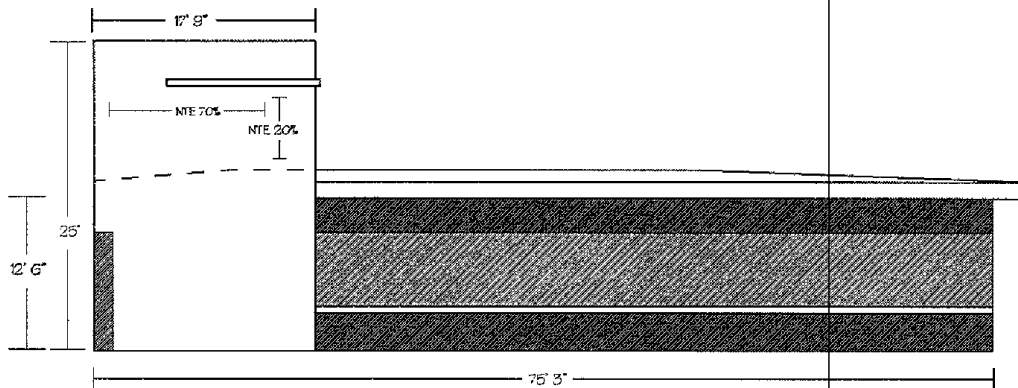

BUILDING C- SOUTH ELEVATION

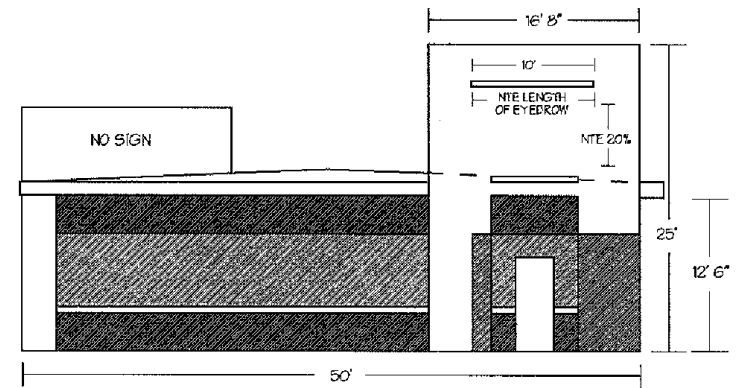

BUILDING C- WEST ELEVATION

# building D

Address: 1930 Outlet Center Drive

Sign must be a minimum of 12" away from the edges of the building and a minimum of 12" from the top of the building and/or architectural feature.

Allowable sign areas are those that have Not To Exceed (NTE) measurements on them.

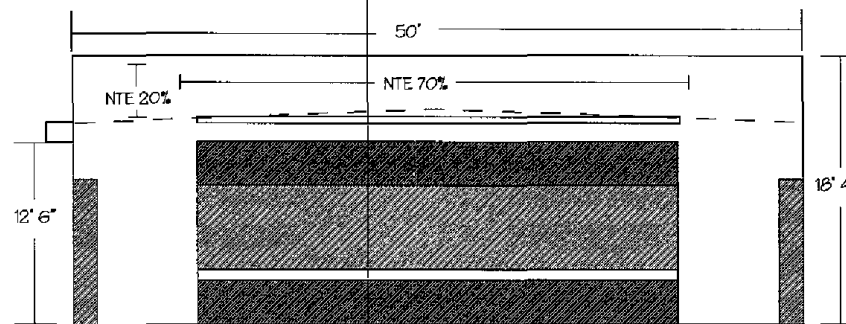

BUILDING D- NORTH ELEVATION

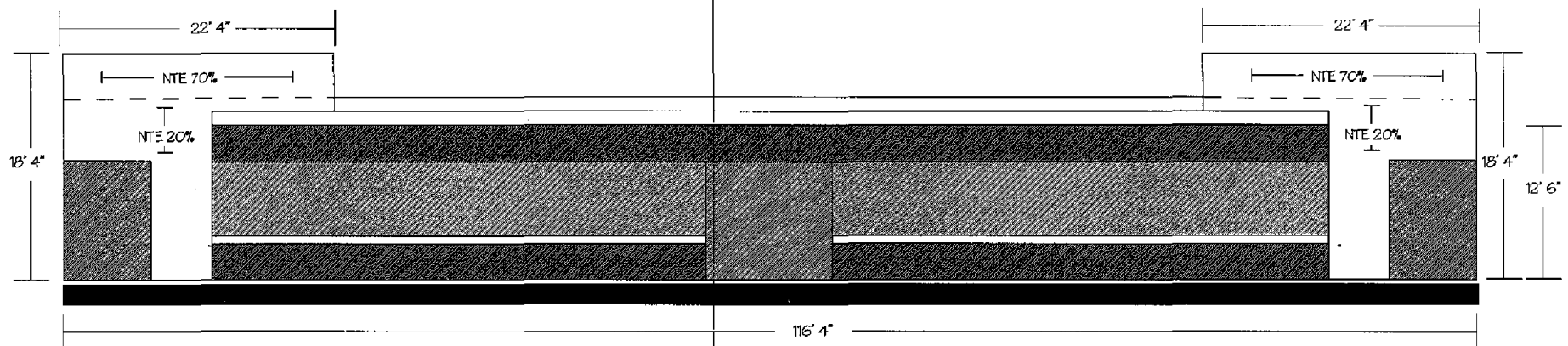

BUILDING D- EAST ELEVATION

# building D

Address: 1930 Outlet Center Drive

Sign must be a minimum of 12" away from the edges of the building and a minimum of 12" from the top of the building and/or architectural feature.

Allowable sign areas are those that have Not To Exceed (NTE) measurements on them.

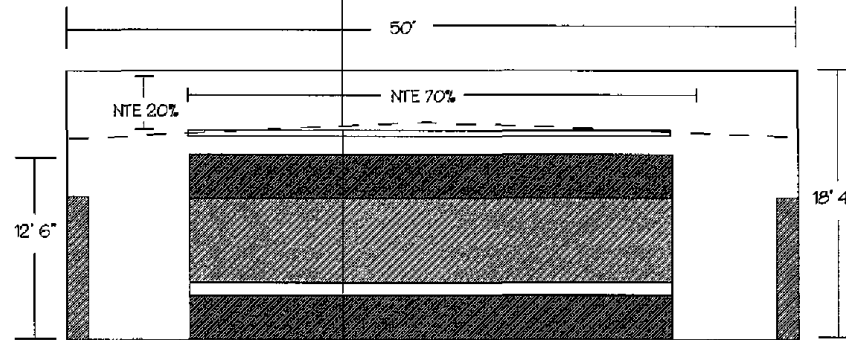

BUILDING D- SOUTH ELEVATION

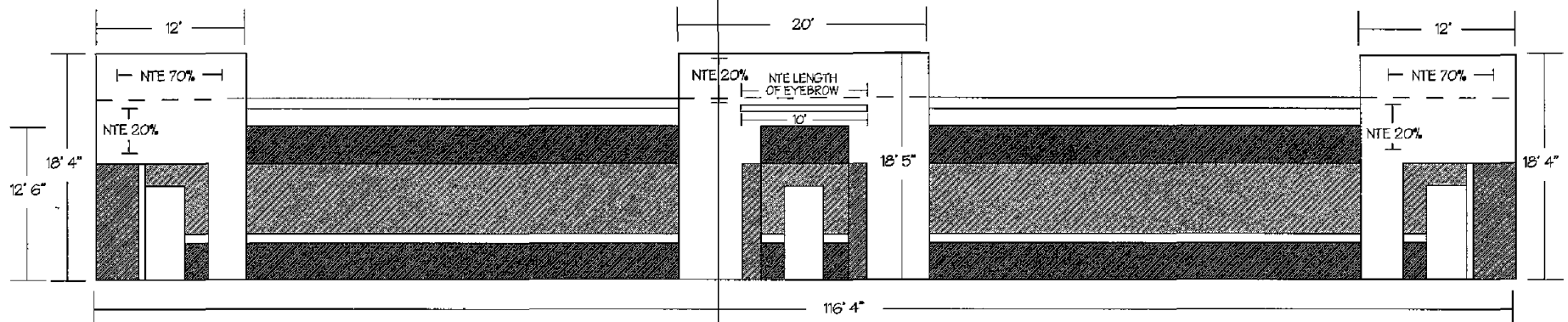

BUILDING D- WEST ELEVATION

# allocation table

| <b>Address</b>            | <b>Aggregate Sign Area (Sq. Ft.)</b> |
|---------------------------|--------------------------------------|
| 1900                      | 337                                  |
| 1910                      | 79                                   |
| 1920                      | 79                                   |
| 1930                      | 54                                   |
| Aggregate Signage         | 549                                  |
| Total Signage Proposed    | 549                                  |
| Maximum Allowable Signage | 549                                  |

## Sign Criteria

Monument sign- No monument or freestanding sign proposed for this development.

Tenant Signs- Location: Letters to be located in the horizontal sign band indicated on the exterior elevations. This occurs at one location per tenant - on the primary street frontage where entry doors are located.

Max. Letter Height: 14 inches

Color & letter type: Letter shall be individual gator (foam (black), type face to be Helvetica medium or comports to tenants type face.

Max. area: The area shall be defined as a rectangle drawn around and encompassing all components of each letter in the sign. The maximum area of sign per tenant is 2 sq. ft. of sign area per lineal foot of building frontage facing the street & occupied by the particular tenant. There is a maximum of 300 sq. ft. of signage per building to be divided proportionately between the tenants.





MERIDIAN OFFICE PARTNERS





## MERIDIAN OFFICE PARTNERS